

SARASIN-RSBD

Excellent
Engineering
Solutions

Portable Spring Loaded Safety Relief Valves
Series 9

WEIR



Introducing Weir

Weir provides critical service and safety valves, specialist pumps and service support to flow control and rotating equipment. Our world-wide reputation is based on engineering excellence applied to a comprehensive range of specialist products and effective customer support.

We have the capability to deliver complete valve solutions for major projects in the power generation, oil and gas exploration and general industrial sectors. Our global network of service operations specialise in the maintenance, upgrade and management of power and industrial assets at customer sites.

Quality assurance

Weir operates quality programmes to cover the full scope of their activities. Comprehensive quality systems have been developed to serve the power, oil and gas and industrial markets which they serve.

The company holds approvals to or complies with:

- ASME Section III 'N', 'NPT', 'NV'
- ASME Section I 'V'
- ASME Section VIII 'UV'
- EN ISO 9001: 2008
- EN ISO 14001: 2004
- OHSAS 18001: 2007
- API Q1 TO API LICENCES API 6D (6D-0182) AND API 6A (6A-0445)
- API STD 520
- API STD 526
- API STD 527
- API STD 2000
- ISO 4126



6A-0445
6D-0182

The Quality systems have been approved for the supply of products to meet the requirements of the Pressure Equipment Directive (PED) and compliance modules A, D1, H, B&D have been applied in categories I through IV respectively.

The company is committed to compliance with legislation and has an established environment and health and safety policy.

An ongoing commitment to customer care is met through the process of continuous improvement and the further development of our systems and processes towards meeting ISO 9001.

Material testing service available

- Non-destructive examination by radiography, ultrasonics, magnetic particle and liquid penetrant.
- Chemical analysis by computer controlled direct reading emission spectrometer.
- Mechanical testing for tensile properties at ambient and elevated temperatures, bend and hardness testing. Charpy testing at ambient, elevated and sub-zero temperatures.

Valve testing facilities

All pressure containing items are hydrostatically tested, seat leakage tested and functionally tested. In addition, gas, packing emission, cryogenic and advanced functional testing can be arranged.



Further technical information can be obtained from our Web site: <http://www.weirpowerindustrial.com>



Weir Power & Industrial France

SARASIN-RSBD

Weir manufactures the Sarasin-RSBD range of pressure safety valves and safety devices for oil and gas, petrochemical and chemical industries, pipelines, thermal and nuclear power plants, sugar refineries and pulp mills.



Machining facility



Steam test facility

The Sarasin-RSBD range of products is manufactured in accordance with ASME, API and ISO standards and therefore can meet most of worldwide customers requirements. The company holds approvals or complies with:

EN ISO 9001:2008

EN ISO 14001:2004

OHSAS 18001:2007

PED 97/23/EC Module B+D Category IV

ATEX 94/9/EC

ASME Section I 'V' - ASME Section VIII 'UV'

API STD 520 - API STD 526 - API STD 527

API STD 2000

ISO 4126

SELO

ROSTECHNADZOR

KGS

Specifically, Weir can design and manufacture special valves to meet special customer requirements.

CONTENTS

Introduction	4
Dimensions	5
Materials	7
Accessories	10
Codifications	12
Applications	13

The 9 Series valves are designed and manufactured in compliance with American and European standards (ASME B&PVC Section VIII Division 1, EN ISO 4126 Part 1).

The 9 Series comply with most overpressure protection requirements in the following industries: oil & gas, petrochemical, chemical and many other general industries.

General

- Full lift
- Full Nozzle
- Adjustable blowdown
- Use on Gas, Liquids, Steam
- Size: ½" to 1" ½
- Set Pressure up to 430 barg (6250 psig)
- Temperature: up to 400°C (752°F)

Connections

- Screwed
 - Inlet: NPT male (female on request)
BSP male
 - Outlet: NPT female
BSP cylindrical female
- Flanged
 - Inlet: Loose captive flange
 - Outlet: Screwed or flange
 - Type: ASME B16.5, EN 1759-1, EN 1092-1,
Other standard on request

Concept

- Adjusting ring for perfect popping and blowdown adjustment
- Metal/metal seating

Construction

- Body: Carbon steel (SA 216 Gr WCC)
Stainless steel (SA 351 Gr CF3M)
Exotic material
- Trims: Stainless steel
Exotic material

Options

- Packed lifting lever
- Test gag
- Bellows (*metal seat - D & F orifices*)
- Soft seat
- Balanced Piston (*soft seat*)



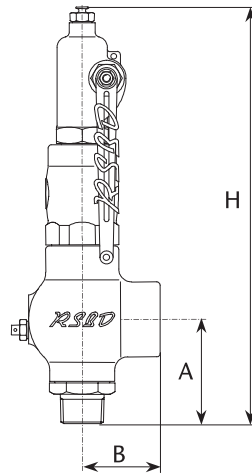

Orifices & Dimensions

NB Certified Flow Coefficient

Gas: 0.823

Liquid: 0.632

Orifice	Type	Inlet		Screwed Outlet		Dimensions			Weight (Kg)
		Max Set Pressure barg	psig	Max Back Pressure barg	psig	A mm	B mm	H mm	
B actual area : 0.283 cm ² /0.044 in ²	1/2" x 1/2"	155.2	2250	51.7	750	43.5	40	242	1.8
	1/2" x 1"	155.2	2250	20.0	290	47.5	40	242	1.8
		431.0	6250	51.7	750	63.0	85	344	6.5
	3/4" x 1"	155.2	2250	20.0	290	50.5	40	245	1.8
		431.0	6250	51.7	750	63.0	85	344	6.5
1" x 1"	155.2	2250	20.0	290	50.5	40	245	2	
	431.0	6250	51.7	750	69.0	85	350	6.7	
D actual area : 0.801 cm ² /0.124 in ²	3/4" x 1"	103.4	1500	51.7	290	64.0	50	255	2
		258.6	3750	51.7	750	63.0	85	344	6.5
	1" x 1"	103.4	1500	51.7	290	70.0	50	262	2.2
		258.6	3750	51.7	750	69.0	85	350	6.7
E actual area : 1.431 cm ² /0.222 in ²	3/4" x 1"	51.7	750	20.0	290	64.0	50	255	2
		155.2	2250	51.7	750	63.0	85	344	6.5
	1" x 1"	51.7	750	20.0	290	70.0	50	262	2.2
		155.2	2250	51.7	750	69.0	85	350	6.7
F actual area : 2.270 cm ² /0.352 in ²	1" x 1 1/2"	51.7	750	20.0	290	91.0	60	325	4.3
	1 1/2" x 1 1/2"	51.7	750	20.0	290	91.0	60	325	4.3
G actual area : 3.664 cm ² /0.568 in ²	1" x 1 1/2"	20.0	290	20.0	290	91.0	60	325	4.5
	1 1/2" x 1 1/2"	20.0	290	20.0	290	91.0	60	325	4.5

Orifices & Dimensions

NB Certified Flow Coefficient

Gas: 0.823

Liquid: 0.632

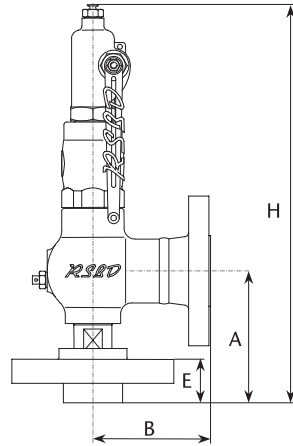

Orifice	Type	Flanged				Outlet		Dimensions				Weight (Kg)
		Max Set Pressure barg	psig	Class ASME (1)	Class ASME (1)	Max Back Pressure barg	psig	A mm	B mm	E mm	H mm	
B actual area : 0.283 cm ² /0.044 in ²	1/2" x 1"	19.7	285	150	150	19.7	285	90	85	26.8	285	3.6
		51.0	740	300						29.8		
		102.1	1480	600						29.8		
		153.1	2220	900						38.5		
		255.5	3705	1500						45.8		
	3/4" x 1"	425.5	6170	2500	300	51.0	740	115	120	38.5	400	10.2
		19.7	285	150						45.8		
		51.0	740	300						31.3		
		102.1	1480	600						31.3		
		153.1	2220	900						41		
	1" x 1"	255.5	3705	1500	300	51.0	740	115	120	41	300	6.6
		425.5	6170	2500						47.4		
		19.7	285	150						41		
		51.0	740	300						33.1		
		102.1	1480	600						33.1		
D actual area : 0.801 cm ² /0.124 in ²	1/2" x 1"	153.1	2220	900	150	19.7	285	90	85	29.9	290	4
		255.5	3705	1500						33.1		
		19.7	285	150						31.3		
		51.0	740	300						31.3		
		102.1	1480	600						41		
	3/4" x 1"	153.1	2220	900	300	51.0	740	115	120	41	400	10.9
		255.5	3705	1500						41		
		19.7	285	150						29.9		
		51.0	740	300						33.1		
		102.1	1480	600						33.1		
	1" x 1"	153.1	2220	900	300	51.0	740	115	120	50.6	400	10.9
		255.5	3705	1500						50.6		
		19.7	285	150						28.3		
		51.0	740	300						31.3		
		102.1	1480	600						31.3		
E actual area : 1.431 cm ² /0.222 in ²	3/4" x 1"	153.1	2220	900	300	51.0	740	115	120	41	290	4.2
		255.5	3705	1500						31.3		
		19.7	285	150						31.3		
		51.0	740	300						41		
		102.1	1480	600						41		
	1" x 1"	153.1	2220	900	300	51.0	740	115	120	41	400	11
		255.5	3705	1500						31.3		
		19.7	285	150						29.9		
		51.0	740	300						31.1		
		102.1	1480	600						31.1		
F actual area : 2.270 cm ² /0.352 in ²	1" x 1 1/2" (2)	153.1	2220	900	150	19.7	285	115	120	44	350	7.8
		255.5	3705	1500						15.8		
		19.7	285	150						19.1		
	1 1/2" x 1 1/2"	51.0	740	300	150	19.7	285	115	110	33.1	350	8.5
		102.1	1480	600						36.2		
		153.1	2220	900						36.2		
G actual area : 3.664 cm ² /0.568 in ²	1" x 1 1/2" (2)	19.7	285	150	150	19.7	285	115	110	15.8	350	7.8
		51.0	740	300						15.8		
	1 1/2" x 1 1/2"	19.7	285	150	150	19.7	285	115	110	33.1	350	8.7
		51.0	740	300						33.1		

(1) Comply with EN 1759-1 - EN 1092-1 (Former DIN) on request. (2) Integral flange for ASME B16.5 connections

9 SERIES – Standard configuration

Materials for standard applications, high temperature, low temperature and corrosive fluids.

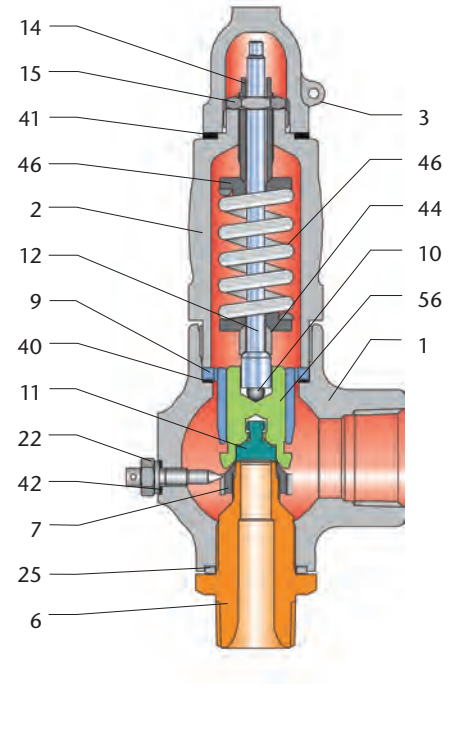
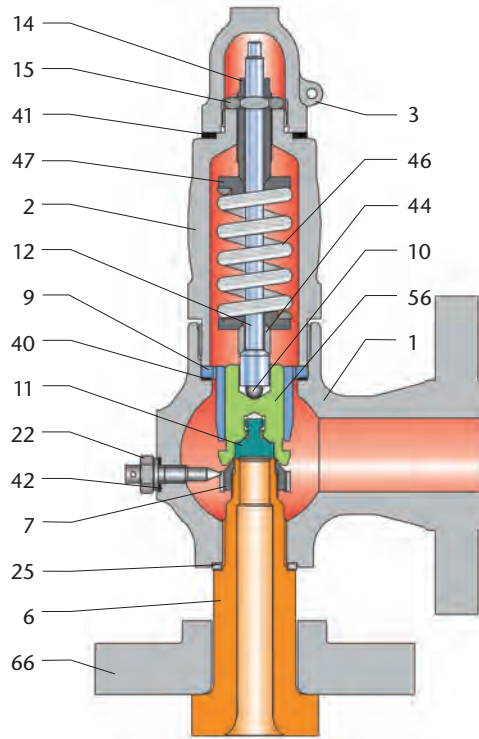

Tag	Designation	Standard Material	
		Carbon Steel Material Code A	Stainless Steel Material Code X
1	Body	SA 216 Gr WCC	SA 351 Gr CF3M
2	Bonnet	CS LF2 or SS 316L	SA 351 Gr CF3M or SS 316L
3	Cap	SA 216 Gr WCC or SS 316L	SA 351 Gr CF3M or SS 316L
6	Nozzle (Base)	SS 316L	SS 316L
7	Adjusting Ring	SA 351 Gr CF3M	SA 351 Gr CF3M
9	Guide	SS 17.4 PH	SS 17.4 PH
10	Ball	CS	SS
11	Disc	SS 316L	SS 316L
12	Spindle	13% Cr or SS 316L	SS 316L
14	Adjusting Screw	SS 316L	SS 316L
15	Lock Nut	SS 316L	SS 316L
22	Adjusting Ring Screw	SS 316L	SS 316L
25	Nozzle Gasket	SS 316L	SS 316L
40-41-42	Gasket	SS	
44	Spacer	SS 316L	SS 316L
46	Spring	Alloy X750	
47	Spring Washers (Upper & Lower)	CS	SS 316L
56	Disc Holder	SS 316L	SS 316L
66	Lapped Flange	SA 105 LF2	SS 316L

Notes:
 1. Stellite seat for 900# and over for B and D orifices.
 2. Other materials (such as superalloy) on request.

9 SERIES – Special configuration

Materials for Cryogenic and Liquefied Natural Gas.

Liquefied Natural Gas and more generally cryogenic applications require special features for the internal materials.

End-users and contractors must be aware that any leakage on cryogenic applications could create an ice ball around the seat and affect the pressure safety valve reliability.

In order to prevent any leakage due to seat damage, Weir recommends the use of soft seat.

Tag	Designation	Material for Cryogenics and LNG below -46°C
1	Body	SA 351 Gr CF3M or SS 316L
2	Bonnet	SA 351 Gr CF3M or SS 316L
3	Cap	SA 351 Gr CF3M or SS 316L
6	Nozzle	SS 316L
7	Adjusting Ring	SA 351 Gr CF3M
9	Guide	SS 316L
10	Ball	SS
11	Disc	SS 316L
11a	Soft Seat	See Soft Disc Material Table
12	Spindle	SS 316L
14	Adjusting Screw	SS 316L
15	Adj. Screw Locknut	SS 316L
16	Washers	SS 316L
22	Adjusting Ring Screw	SS 316L
25	Nozzle Gasket	SS 316L
33	Thermal Spacer	SS 316L
34	Thermal Barrier	Bakelite®
35	Spacer Ring	Thermoglide
36	Ball	SS
40	Guide Gasket	SS
41	Cap Gasket	SS
42	Adj. R. Screw Gasket	SS
44	Spacer	SS 316L
46	Spring	Alloy X750
56	Disc Holder	SS 316L
66	Lapped Flange	SS 316L
83	Retaining Screw	SS 316L

Soft Seat

Set Pressure	Soft Material
1 to 26 barg	PTFE
26 to 66 barg	PCTFE
66 to 200 barg	PEEK

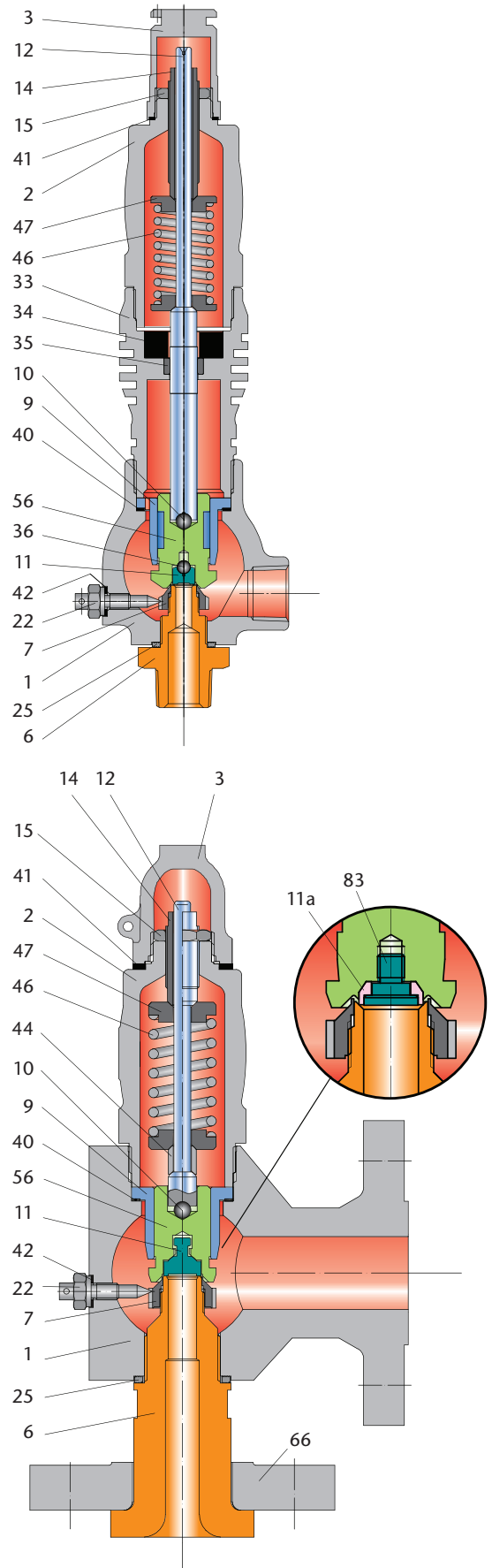

9 SERIES – Special Configuration

Materials for Corrosive and Sour Gas Services

Many process streams in the oil and gas industry contain enough H₂S to cause sulfide stress cracking (SSC) in susceptible materials. It exists in two different domains in which two different standards may be applicable:

- Oil and Gas production: NACE MR0175/ISO 15156
 - Part 1 - 2001: General principles for selection of cracking-resistant materials
 - Part 2 - 2003: Cracking-resistant carbon and low alloy steels, and the use of cast irons.
 - Part 3 - 2003: Cracking-resistant CRAs (corrosion-resistant alloys) and other alloys.
- Oil and gas refining: NACE MR0103

The last revisions of NACE MR0175/ISO 15156 shows results of the inadequacy of some standard materials commonly used in the oil and gas industry. We then highlight this point and ask the end-user to clearly specify the condition of use (fluid details, pressure and temperature) in order to be able to select acceptable materials.

Weir manufactures a large variety of valves used in sour service. Based on our experience and the last edition of the standards, the definition of the actual critical components in a pressure safety valve should be mutually agreed between the purchaser and Weir.

Please note, materials are applicable for NACE MR0175 / ISO 15156 according to the different paragraphs of the standard. As a first approach, we can note the following:

Materials	Paragraph
SA 352 Gr LCC	MR0175/ISO 15156-2 ¶ A2-1-2
SA 216 Gr WCC	MR0175/ISO 15156-2 ¶ A2-1-2
SA 217 Gr WC6	MR0175/ISO 15156-2 ¶ A2-1-2
SA 479 Gr 316L	MR0175/ISO 15156-3 ¶ A2-2
UNS S31803	Table 2 MR0175/ISO 15156-3 ¶ A7-2
UNS N06625	Table 24 MR0175/ISO 15156-3 ¶ A4-2
UNS N07750	Table 13 MR0175/ISO 15156-3 ¶ A2-9
	Table 36

As an example of selection, Weir can advise the following valve configuration. The conditions here are not so restrictive: temperature limited to 149°C (300°F).

SGA application : applicable on primary side only

Part N°	Part Name	Material	Applicable Paragraph
1	Body	SA 216 Gr WCC	MR0175/ISO 15156-2 ¶ A2-1-2
6 + 11	Nozzle & Disc	SS 316L	MR0175/ISO 15156-3 ¶ A7-2 Table A24
	Other parts	Standard	

Note : Above 233°C (500°F), parts 6-11 will be proposed in UNS N06625 (Alloy 625).

SGB application : applicable on primary and secondary sides

Part N°	Part Name	Material	Applicable Paragraph
1	Body	SA 216 Gr WCC	MR0175/ISO 15156-2 ¶ A2-1-2
2	Bonnet	SA 216 Gr WCC	MR0175/ISO 15156-2 ¶ A2-1-2
4	Cap	SA 216 Gr WCC	MR0175/ISO 15156-2 ¶ A2-1-2
6 + 11	Nozzle & Disc	SS 316L	MR0175/ISO 15156-3 ¶ A7-2 Table A24
9	Guide	SS 316L	
19	Balanced Bellows	UNS N06625 (Alloy 625)	MR0175/ISO 15156-3 ¶ A4-2 Table A13
46	Spring	Alloy X750	
	Other parts	Standard	

Note : Above 233°C (500°F), parts 6-11-19 will be proposed in UNS N06625 (Alloy 625).

Accessories

1) Packed lifting lever

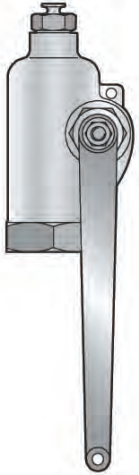

2) Balanced Bellows
(D & F Orifices)

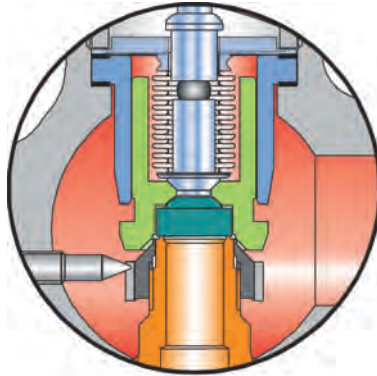

3) Test gag

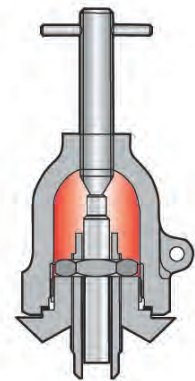

4) Butt-Welding fittings inlet & outlet
(3 pieces union couplings)

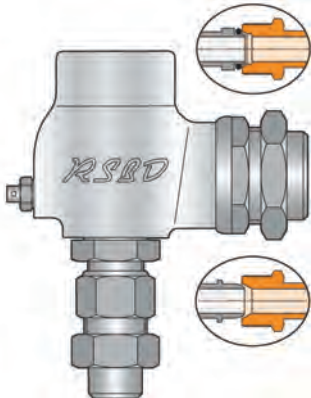

Type V
on request

Type S
Standard

5) Inlet "Clamp" connection

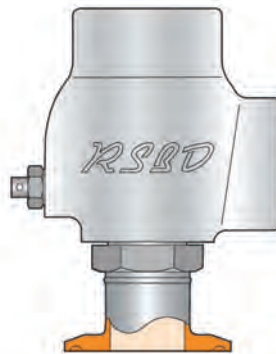

6a) Conventional Soft seat

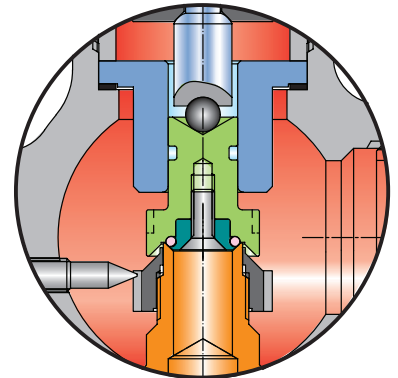

6b) Balanced Soft seat

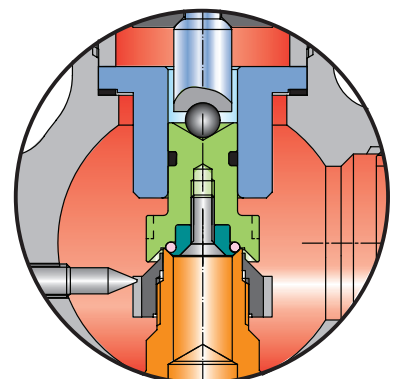

Soft Seat

Set Pressure	Soft Material
1 to 26 barg	PTFE
26 to 66 barg	PCTFE
66 to 200 barg	PEEK

Note: these values are applicable upto 25 °C - for higher temperature, please consult the factory.

Special

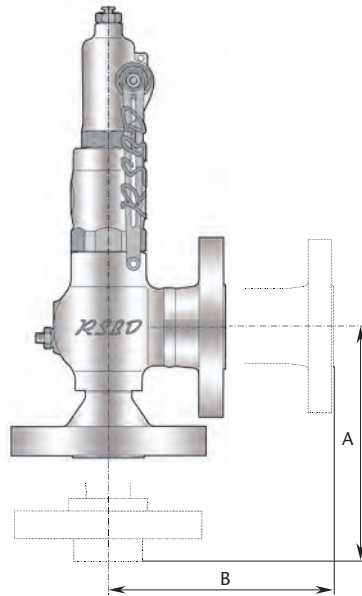

A & B dimensions
on request

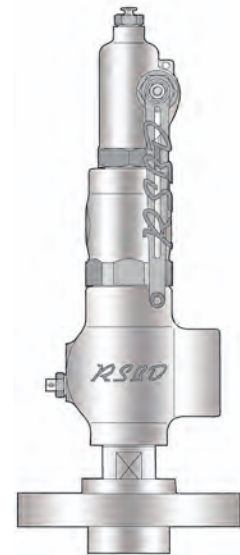

Mixed
connections

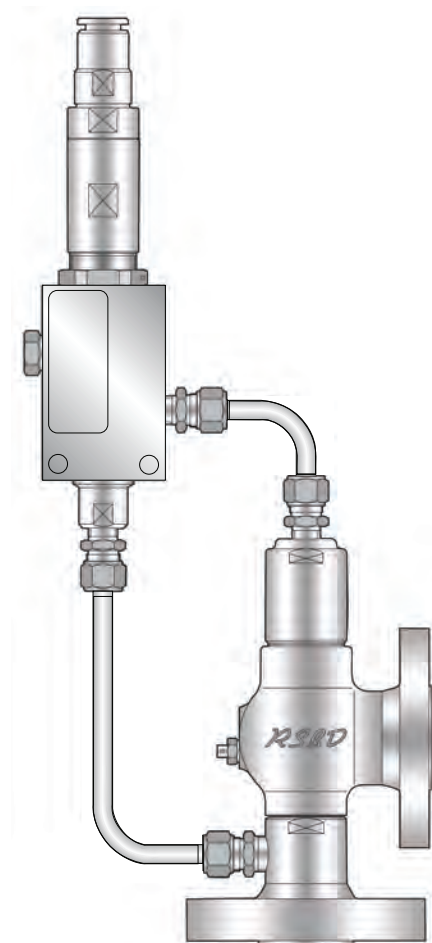

Pilot operated type
(71 series)
(See our POSRV brochure)

Notes:

- 1 - Weir can produce any forged body arrangement in order to meet high pressure or temperature and special dimensions.
- 2- On application, Weir can supply the 18 Series (special) up to 990 barg (14,358 psig) with an orifice C of 0.385 cm² (0.0596 in²). This valve is CE marked (PED 97/23/CE)

Codification

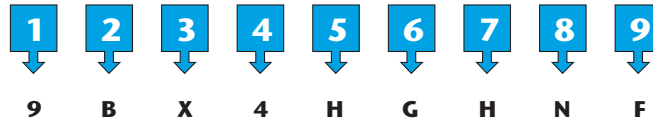

- 1** → **Type : 9**
- 2** → **Orifice :**
– (B-D-E-F-G)
- 3** → **Material of Construction :**
– 10 : A 351 Gr CF3M (Cryogenic)
– A : A 216 Gr WCC
– X : A 351 Gr CF3M (Std Application)
– A201 to A206 : Alloy 20
– AL1 & AL6 : Alloy 625
– AY1 & AY6 : Alloy 825
– AV1 & AV6 : Alloy 254 SMO
– CN1 & CN7 : A 351 Gr CN3MN
– D1 & D6 : Duplex
– H1 & H6 : Alloy C
– M1 & M6 : Alloy 400
– SD1 & SD6 : Superduplex
– MRA & MRB : NACE MR0103
– SGA & SGB : NACE MR0175 / ISO 15156
- 4** → **Inlet Pressure Class (ASME):**
– 1: 150#
– 2: 300#
– 3: 600#
– 4: 900#
– 5: 1500#
– 6: 2500#
- 5** → **Spring Material :**
– H: Alloy X750
- 6** → **Inlet Size :**
– F: 1/2"
– G: 3/4"
– H: 1"
– K: 1 1/2"
- 7** → **Outlet Size :**
(B Orifice only)
– F: 1/2"
– H: 1"
- 8** → **Connections :**
– A: ASME B16.5 (Equivalent to EN 1759-1)
– P: EN 1092-1
– K: Inlet Male con. BSP / Outlet Female cyl. BSP
– N: Inlet Male NPT / Outlet Female NPT
– N2: Inlet Female NPT / Outlet Female NPT
– Uα: 3 piece union
– Z: Other
- 9** → **Options :**
– A: Without option
– F: Packed lifting lever
– L: Lapped flange at the inlet
– P: Bellows
– V: Test gag
– Z: Others

The information is given for guidance only and can be revised without prior notice.

Spring Loaded Safety Relief Valves

Body in carbon steel, stainless steel, alloy and exotic materials; with bellows, lever and other accessories, to ensure suitability for all service conditions.



Starflow SS (steam only)
ASME Section VIII Div. 1
(UV Stamp)
API Std 526
Full Nozzle - Enlarged guide
Inlet size : 1" to 12"
Rating : 150# to 2500#
Temp : up to 540°C



Starflow P3/P4/P5
ASME Section VIII Div. 1
(UV Stamp)
API Std 526
Full Nozzle
Inlet size : 1" to 12"
Rating : 150# to 2500#
Temp : -196°C up to +540°C

Pilot Operated Safety Relief Valves

The Sarasin-RSBD pilot-operated safety relief valve is an autonomous valve. It does not need any auxiliary source of power to operate. The advanced technology of Sarasin-RSBD valves has been adopted by the nuclear industry, French and U.S. Navies and by the Oil & Gas industries. It is complementary to the range of spring-loaded safety relief valves and covers a wide field of applications including severe conditions.



76 Series
Full nozzle
API spring loaded SRV dimensions



78 Series
Semi nozzle
API POSRV dimensions



86 Series
Hot service - Full nozzle
API spring loaded SRV dimensions
Set pressure : up to 180 barg
Temp : up to 550°C

Advantages of the Sarasin-RSBD Pilot-operated safety relief valve

- leak-free pilot
- on-off opening, fully open or closed (limited maintenance)
- perfect tightness (no production loss)
- perfect operation, even with capacities smaller than those rated for all types of fluids
- excellent repeatability and reliability
- adjustable blowdown (pop action)
- no pressure/flow limit
- with additional equipment (solenoid valve), the safety relief valve can be used as a discharge valve.

To meet the most varied requirements, Sarasin-RSBD selects the appropriate pilot detector for the safety relief valve required (semi or full nozzle, with bellows, piston etc.)



63 Series
ISO 4126
Semi-nozzle
Inlet size : ¼" to 10"
Rating : 150# to 300#
Temp : -196°C up to +330°C



9 Series
ASME Section VIII Div. 1
Portable SRV - Full nozzle
Screwed/Flanged/Welded
Size : ½" to 1 ½"
Rating : 150# to 2500#
Temp : -196°C up to +400°C



71 Series
Portable - Full nozzle



Starvalve Changeover Valves
Low pressure drop COV
Standard COV
Combined valve with linkage system
Sizes : ½" - 10"
Pressure : up to 100 barg
Temp : -196°C up to +427°C
Mat : CS - SS



Gas - Liquid
Modulating action



Gas
Pop action



High temperature steam - Gas
Pop action

Weir Power & Industrial France

Rue J.B. Grison - ZI Bois Rigault
62880 Vendin Le Vieil - France
Tel: +33 (0) 3 21 79 54 50
Fax: +33 (0) 3 21 28 62 00
Email: sarasin.rsbd@weirgroup.com

Weir-BDK Valves

Unit WEIR India Pvt Limited
47 / 48, Gokul Road,
Hubli-580030 - Karnataka - India
Tel: +91 836 4248222 / 4248223
Fax: +91 836 2330799
Email: india.sarasin-rsbd@weirgroup.com

Excellent
Engineering
Solutions

