

SARASIN-RSBD

Excellent
Power & Industrial
Solutions

WEIR
POWER & INDUSTRIAL

Pilot Operated Safety Relief Valve

71/76/78/86 Series



Quality assurance (division)

Weir Power & Industrial operates quality programmes to cover the full scope of their activities. Comprehensive quality systems have been developed to serve the power, oil and gas and industrial markets which they serve.

The company holds approvals to or complies with:

- ASME Section III ‘N’, ‘NPT’, ‘NV’
- ASME Section I ‘V’
- ASME Section VIII ‘UV’
- BS EN ISO 9001: 2000
- NF EN ISO 9001: 2000
- NF EN ISO 14001: 2000
- API Q1 TO API LICENCES API 6D (6D-0182) AND API 6A (6A-0445)
- API STD 520
- API STD 526
- API STD 527
- API STD 2000
- ISO 4126



The Quality systems have been approved for the supply of products to meet the requirements of the Pressure Equipment Directive (PED) and compliance modules A, D1, H, B&D have been applied in categories I through IV respectively.

The company is committed to compliance with legislation and has an established environment and health and safety policy.

An ongoing commitment to customer care is met through the process of continuous improvement and the further development of our systems and processes towards meeting ISO 9001:2000.

Valve Testing Facilities

All pressure containing items are hydrostatically tested, seat leakage tested and functionally tested. In addition, gas, packing emission, cryogenic and advanced functional testing can be arranged.

Material testing facilities

- Non-destructive examination by radiography, ultrasonics, magnetic particle and liquid penetrant.
- Chemical analysis by computer controlled direct reading emission spectrometer.
- Mechanical testing for tensile properties at ambient and elevated temperatures, bend and hardness testing. Charpy testing at ambient, elevated and sub-zero temperatures.

Further technical information can be obtained from our Web site: <http://www.weirpowerindustrial.com>

Sarasin-RSBD Pilot Operated Safety Relief Valves

The Sarasin-RSBD pilot-operated safety relief valve is an autonomous valve. It does not need any auxiliary source of power to operate. The advanced technology of Sarasin-RSBD valves has been adopted by the nuclear industry, French and U.S. Navies, Oil & Gas, LNG and Petrochemical industries. It is complementary to the range of spring-loaded safety relief valves and covers a wide field of applications under severe conditions.

Advantages of the Sarasin-RSBD Pilot-Operated Safety Relief Valve

- Leak-free pilot
- Limited maintenance
- Perfect tightness (no production loss)
- Perfect operation even with capacities smaller than those rated with all kinds of fluids
- Excellent repeatability and reliability
- Adjustable blowdown
- No pressure/flow limit
- With additional equipment (solenoid valve), the safety relief valve can be used as a discharge valve.
- Perfect operation on steam with dedicated DCM pilot

CONTENTS

POSRV Introduction	4
POSRV Benefits	5
Standard Features	6
Pop Pilot DGS (gas only)	8
Modulating Pilot DCS (gas & liquid)	10
High Temperature Pilot DCM	13
71 Series	15
76 Series	16
78 Series	25
86 Series	34
Codifications	35

General

Sarasin-RSBD, a world leader in overpressure protection solutions, offers a unique range of pilot operated safety relief valves. Sarasin-RSBD's experience in pressure safety valves, starting at the end of the eighteenth century, has allowed us to develop and to refine the following range of valves:

- Portable POSRV (71 series)
- Full nozzle POSRV (76 series)
- Semi-nozzle POSRV (78 series)
- High temperature steam service full nozzle POSRV (86 series)

The Sarasin-RSBD POSRV range complies with most of the industrial applications met nowadays: offshore, refining, LNG terminals, etc. However it may be, it has to be recognised a POSRV operates differently from a spring loaded SRV. In this way process characteristics can sometimes cause risks or troubles on spring loaded SRV. A POSRV is often the solution. It is then recommended to the process people to clearly define the overpressure scenario in order to select the correct POSRV with – if necessary – its correct options.

POSRV features

Features	71 Series	76 Series	78 Series	86 Series
ASME B&PVC SECTION VIII Division 1	Yes	Yes	Yes	Yes
API STD 520	Yes (D orifice and above only)	Yes	Yes	Yes
API STD 526	No	Yes (spring loaded SRV tables)	Yes	Yes (spring loaded SRV tables)
API STD 527	Yes	Yes	Yes	Yes
ISO 4126-4	Yes	Yes	Yes	Yes
EN 764-7	Yes	Yes	Yes	Yes
ASME B16.34	Yes	Yes	Yes	Yes
NACE (MR0175/ISO15156 + MR0103)	Yes	Yes	Yes	Yes
PED 97/23/EC	Yes	Yes	Yes	Yes
ATEX 94/9/EC	Yes	Yes	Yes	Yes
Full lift	Yes	Yes	Yes	Yes
Non-flowing pilots	Yes	Yes	Yes	Yes
Pop pilot	Yes	Yes	Yes	Yes
Modulating pilot	No	Yes	Yes	No
Maintenance free design	Yes	Yes	Yes	Yes
Soft seat design	Yes	On application	Yes (S.P. ≤ 100 barg)	Yes
Metal seat design	Yes	Yes	Yes	Yes
Flanged	Yes	Yes	Yes	Yes
Threaded / Welded	Yes	No	No	No

Pressure limits (1)

barg (psig)	71 Series	76 Series		78 Series		86 Series
	Pop	Pop	Modulating	Pop	Modulating	Pop
Minimum	1.8 (26.1)	1.8 (26.1)	2 (29)	1.8 (26.1)	2 (29)	15 (218)
Maximum	431 (6250)	431 (6250)	431 (6250)	431 (6250)	431 (6250)	180 (2610)

Temperature limits (1) for standard configurations

°C (°F)	71 Series	76 Series		78 Series		86 Series
	Pop	Pop	Modulating	Pop	Modulating	Pop
Minimum	-50 (-58)	-196 (-321)	-196 (-321)	-50 (-58)	-50 (-58)	-
Maximum	230 (446)	230 (446)	230 (446)	230 (446)	230 (446)	450 (2) – 550 (3) (842 (2) - 1022 (3))

Note: 1 - For pressure and temperatures above these limits, please consult factory.
 2 - Temperature limit at pilot inlet
 3 - Temperature limit at temperature sense location

Benefits

Increased Profits:

- Avoid chattering (remote opening or modulating)
- Avoid water hammer (modulating)
- Increased production
 - Increased tightness near set pressure
 - Not as sensitive as spring loaded valve on pumping service
 - Soft seat design provides repeatable bubble-tight performance
- Reduced number of valves (compared to Spring loaded)
- Reduced weight and dimensions (compared to spring loaded SRV)
- Reduced product loss (modulating)
- Reduced environmental pollution (modulating)
- Reduced noise (especially on modulating valve)
- Reduced reaction force (especially on modulating valve)
- Reduced maintenance time and cost.

Safe Operation

Flow Control by Nozzle Diameter

In respect of calculation code for flow calculation, there is no risk of massive over-capacity. The high lift provides the sonic flow in the nozzle, not at the curtain area and so preserves the soft seat

Easy Maintenance

- **Top entry design (78 series)**
All maintenance operations can be done without taking out the valve from installation or specific tooling
- **Replaceable nozzle**
In case of heavy damage, nozzles of each valve type can be easily changed: top entry jointing semi-nozzle for 78 series, full nozzle for 71 series, 76 series and 86 series
- **Soft seat and seal**
Quick maintenance with 78 series soft seat (soft seat for 76 series on demand) and seals for all series.

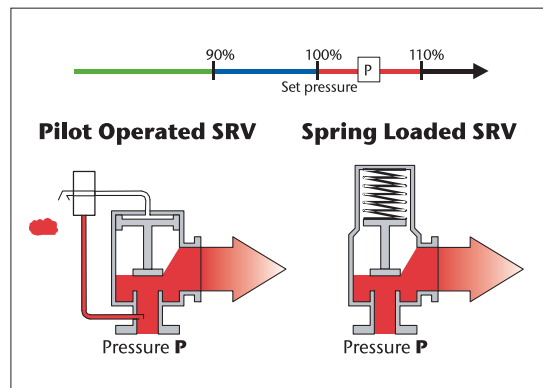
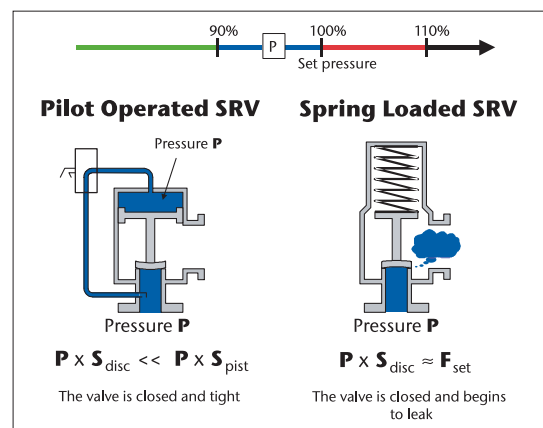
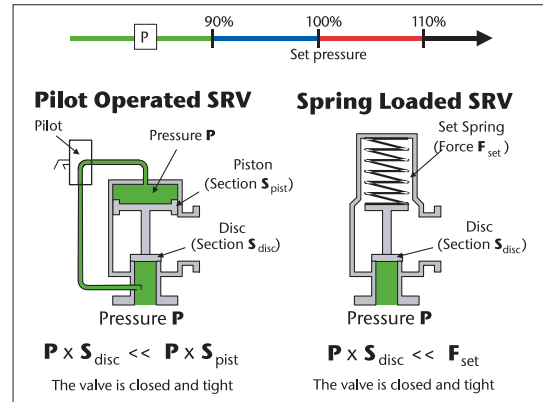

Standard features

Pop Action Pilot

- Immediate full lift at set pressure
- No throttling
- Allows US DOT installation to be set higher than MAOP.

Modulating Action Pilot

- Opening according to the required capacity, without either simmer or chattering
- Reliable operation even on biphasic application
- Auxiliary feeding: Allow the feeding with an alternate clean gas if necessary.

Pop POSRV Operations

Typical lift characteristics

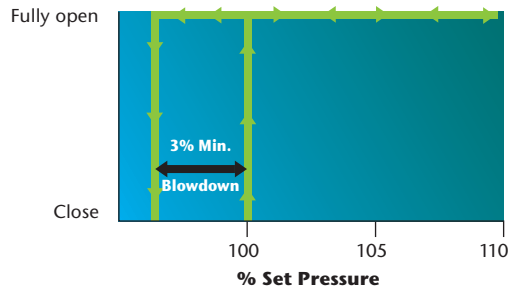

Modulating POSRV Operations

Typical lift characteristics

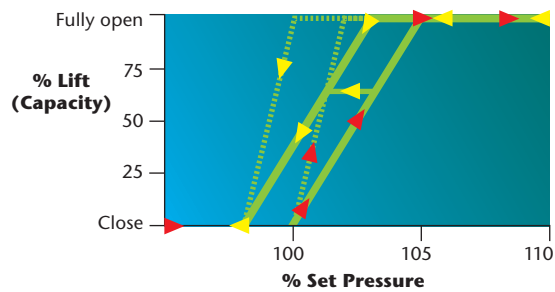

Optional features

Pilot Vented to Body Bowl/Outlet Flange

- To use when fluid cannot be vented to atmosphere (environmental protection)
- Only with modulating pilot (DCS)

Remote Pressure Sensing

Direct pressure sense from protected equipment. It guarantees a stable opening whatever the upstream pressure drop is. In other words, it avoids chattering that can occur on spring loaded design under certain conditions (i.e. PSV remote from protected equipment occurring a pressure drop over the limit of 3% for spring loaded PSV).

Pilot Supply Filter

- Set on the sensing line upstream from the pilot
- Used for fluid with large amount of particles matter
- All stainless steel
- Element can be cleaned.

Heat Exchanger

- Coiled tube for hot temperatures
- Buffer tank for very hot temperature.

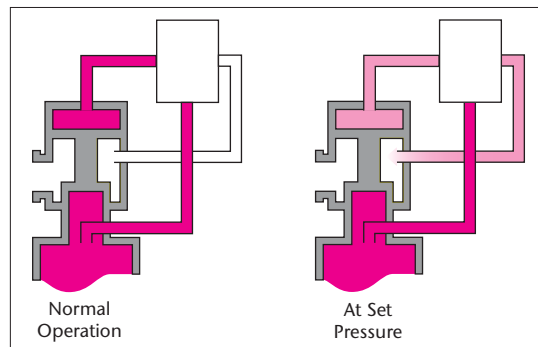

Pilot Vented to Body Bowl / Outlet Flange

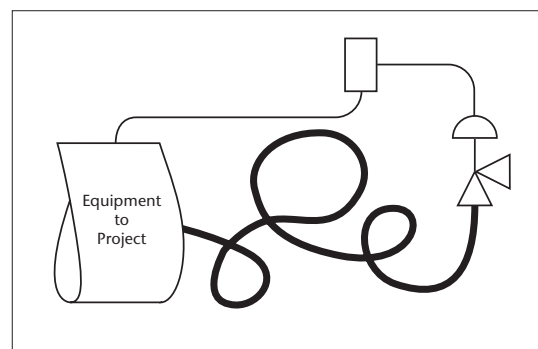

Remote Pressure Sensing

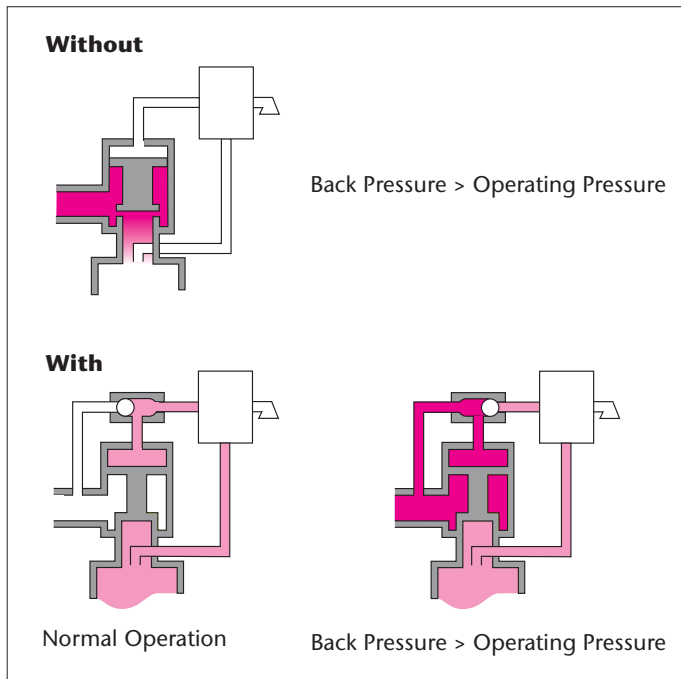

Back Flow Preventer

Back Flow Preventer

- Prevents unexpected reverse flow which occurs through the POSRV, when the exhaust of the pilot is connected onto the outlet flange. In this scenario, the downstream pressure (superimposed back pressure) can be sometimes greater than the sensed pressure (differential pressure). It can occur for many reasons. One of them appears on multiple valves when they are connected on the same collector
- Prevents unexpected vacuum upstream the pilot (i.e. at start-up).

Manual Blowdown Valve (Manual Unloader)

Allows the POSRV to open and depressurise the equipment. It is set on the line between the pilot and the main valve dome. When open, it vents the dome faster than the pilot recharge in pressure. So the dome pressure is reduced and the main valve opens. Nevertheless it is preferred to use the pilot lifting lever (no continuous flow through the pilot exhaust).

Field Test Connection

Testing of set pressure and functioning of main valve during normal operation of the protected device, whatever the equipment pressure level is.

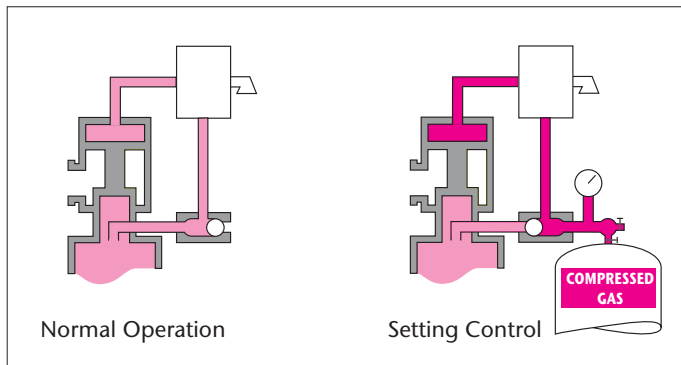

Field Test Connection

Pilot Lifting Lever

Remote Unloader (Remote Opening)

Allows opening the valve from a control room whatever the equipment pressure level is.

Dual Filter

Used to ease maintenance and improve production.

Dual Pilot

Used to ease maintenance and improve production.

Pressure Differential Switch

Senses main valve opening and sends a signal (pneumatic or electric).

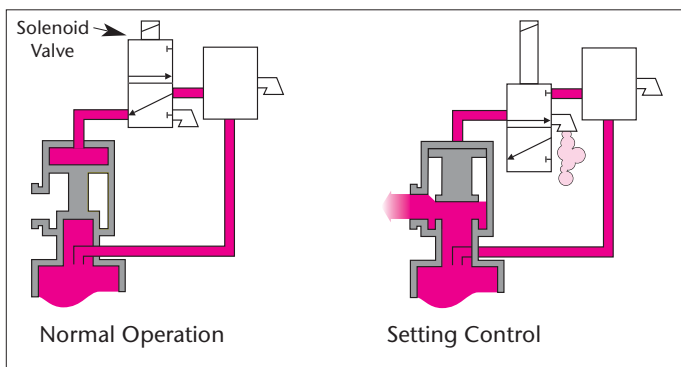

Remote Unloader

Pop Pilot DGS - Gas only

- Non-flowing pop action pilot for gas service
- Due to its simple concept and easy maintenance, this pilot can be used on all standard gas applications
- The immediate full lift of the valve avoids all freezing risk and instability due to up-stream pressure drop
- Non-overpressure and short blow down limit the product loss to the required quantity and reduce opening time.

Features:

- Gas application
- Non-flowing
- Set Pressure range: 1.8 to 431 barg (26.1 to 6250 psig)
- Temperature range: -50°C to +230°C (-58°F to +446°F)
- Maximum Expected Working Pressure: 95% of set pressure

- Pilot Tightness Pressure (before opening): 95% of set pressure
- Immediate full lift of the main valve at set pressure (without overpressure)
- Field adjustable blow down: 2% to 5% of set pressure (factory standard is 5%).

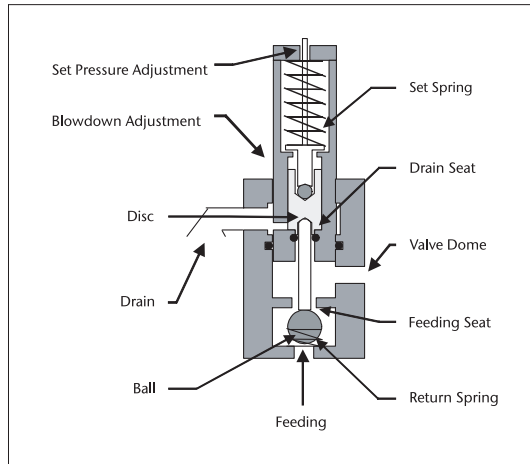

DGS Pilot operations

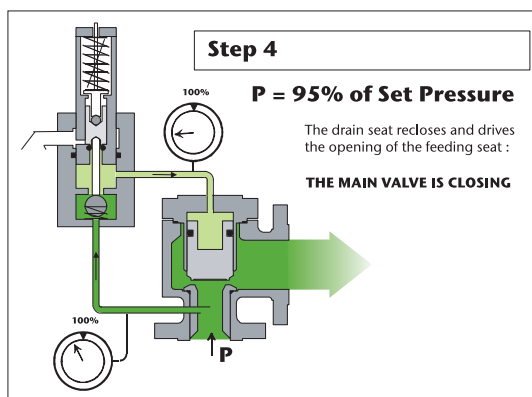
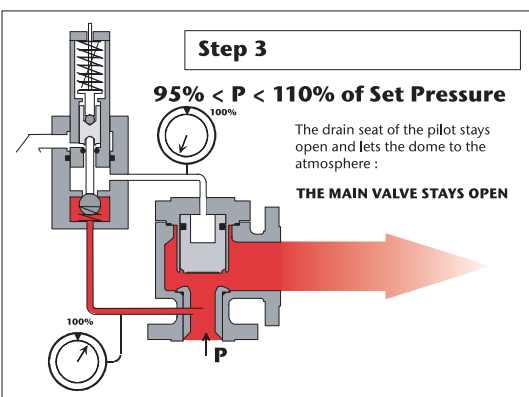
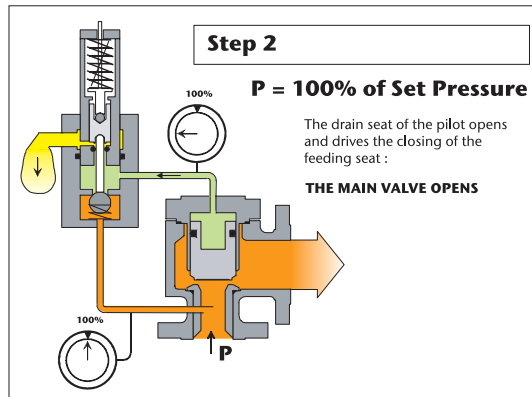
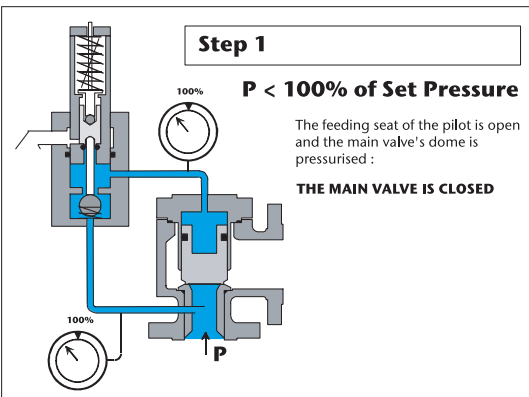

Pop Pilot DGS - Gas only

Materials for standard applications, high temperature, and corrosive fluids.

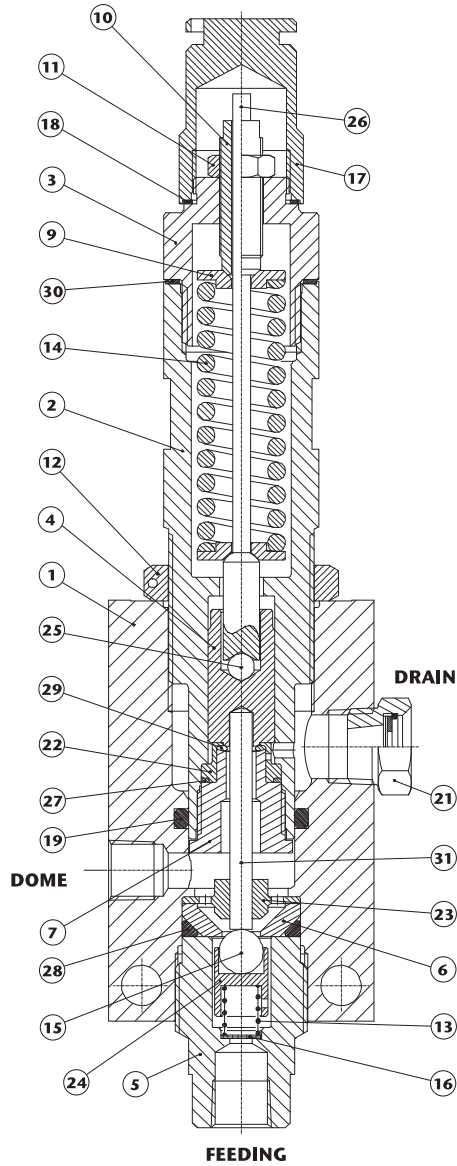

Tag	Designation	Material
1	Body	SS 316L
2	Bushing	SS 316L
3	Bonnet	SS 316L
4	Disc	A 564 Gr 630 (17-4PH)
5	Socket	A 564 Gr 630 (17-4PH)
6	Seat	SS 316L
7	Nozzle	A 564 Gr 630 (17-4PH)
9	Spring washer	SS 316L
10	Adjusting bolt	SS 316L
11	Locknut	SS 316L
12	Nut	SS
13	Ball spring	SS
14	Spring	SS
15	Ball	Ceramic
16	Strainer	SS
17	Cap	SS
18	Cap gasket	Klinger
19	O-ring	(B)
21	Vent	SS
22	Bearing	A 564 Gr 630 (17-4PH)
23	Guide	SS 316L
24	Spacer rod	SS 316L
25	Disc ball	Ceramic
26	Spring spindle	SS 316L
27	O-ring	(A)
28	O-ring	(B)
29	O-ring	(A)
30	Bonnet gasket	Klinger
31	Spindle	A 564 Gr 630 (17-4PH)

(A) : FKM, NBR, EPDM, FFKM

(B) : FKM, EPDM, FFKM, FEP+FKM



Modulating Pilot DCS - Gas and Liquid

- Non-flowing modulating pilot for gas and/or liquid
- Its particularity is to vent the dome only above the set pressure. This original feature operates independently of the maximum working pressure, temporary pressure rising very close to the set pressure (98%) without any discharge from the pilot
- Additionally, the overpressure needed to obtain the full lift of the main valve is less than 3%. This point reduces the risk of simmering and thus reduces seat ageing
- This pilot is to be used on liquid, mixed gas-liquid or gas when “smooth” operation is required.

Features:

- Gas, liquid and mixed phases application
- Non-flowing
- Pressure range: 2 to 431 barg (29 to 6250 psig) - Above please consult the factory
- Temperature range: -50°C to +295°C (-58°F to +563°F) and 600°C (1112°F) with Heat Exchanger
- Maximum Expected Working Pressure: 95% of set pressure
- Pilot Tightness Pressure (before opening): 98% of set pressure
- Modulating upto 3% overpressure, then full lift (for modulating over 3%. please consult factory)
- Blowdown: 2% to 5% of set pressure (factory standard is 5%).

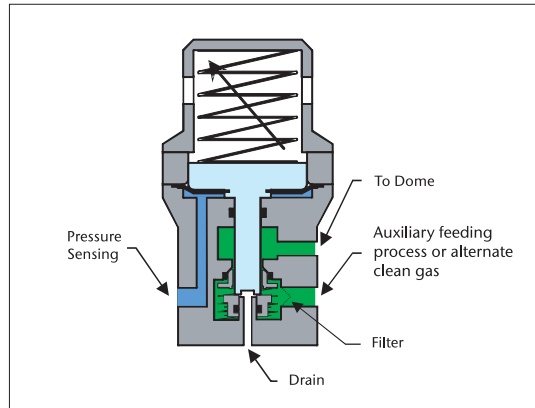

Auxiliary feeding

Pilot’s critical internal parts and main valves dome are isolated from the protected system. Effectively, the line which pressurises the dome is isolated from the one which senses the pressure and so an auxiliary clean fluid can be used to close the main valve. The fail-safe operation is kept (i.e. the main valve will open in the case of auxiliary fluid failure).

DCS Pilot operations

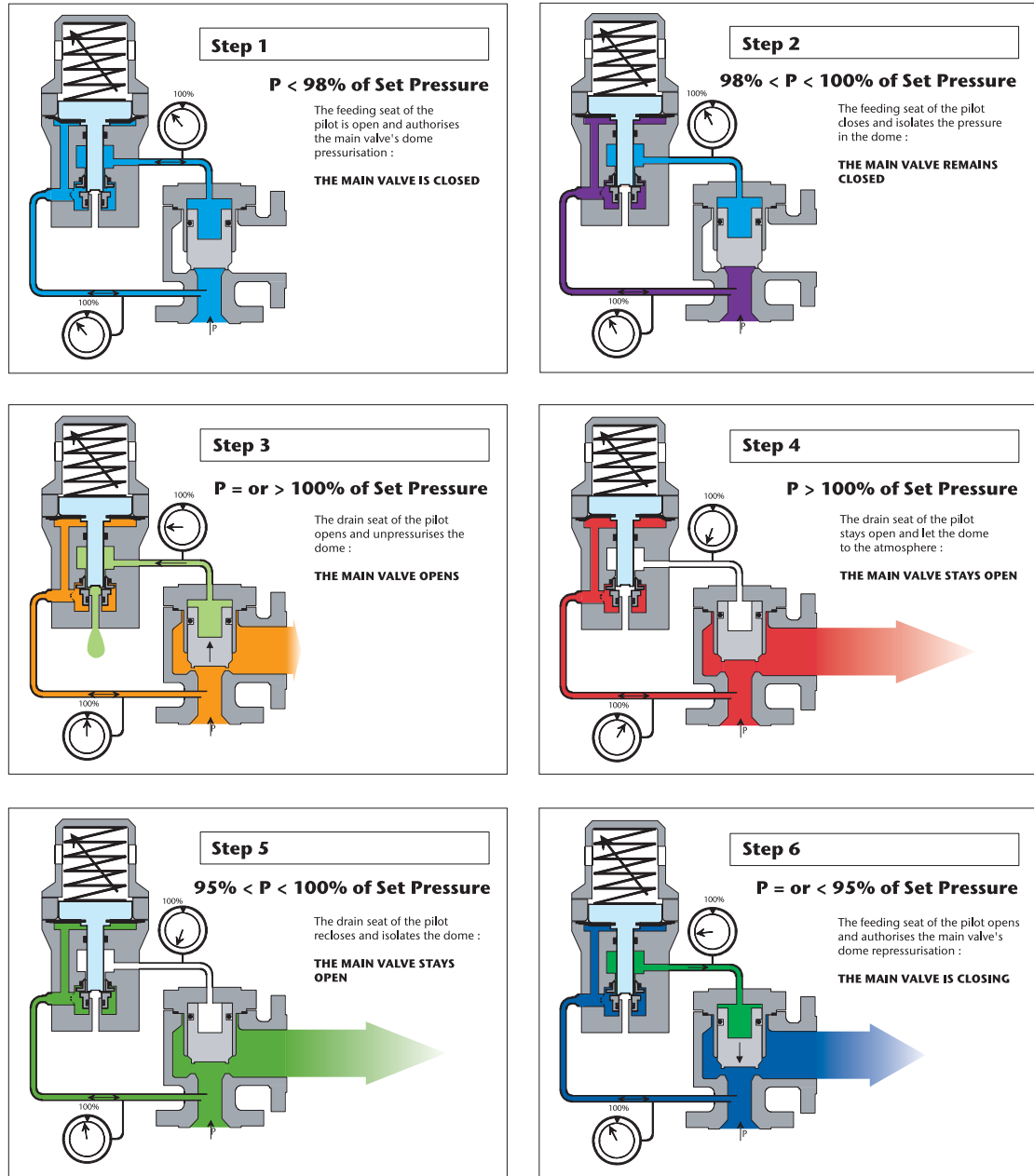

Modulating Pilot DCS - Gas and liquid

Materials for standard applications, high temperature, low temperature and corrosive fluids.

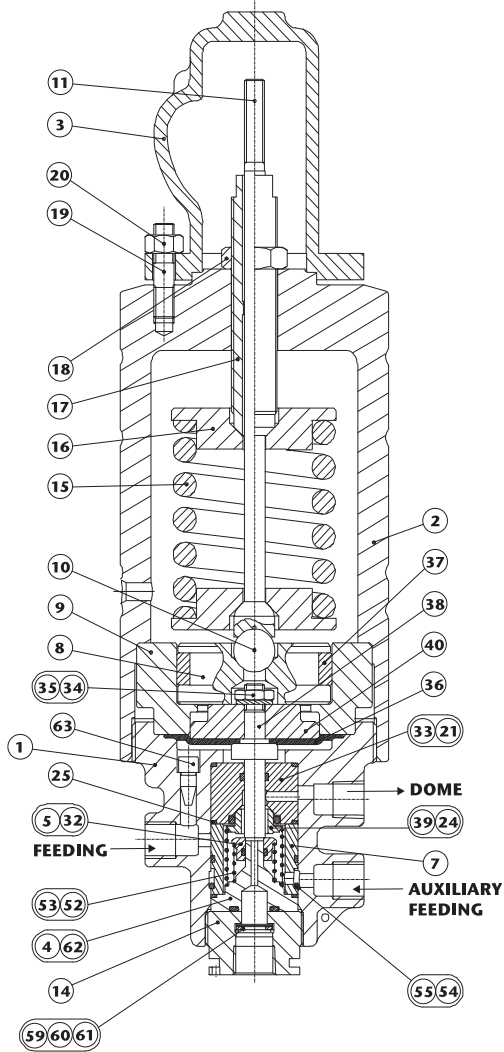

Diaphragm design for pressures upto 36 barg (522 psig)

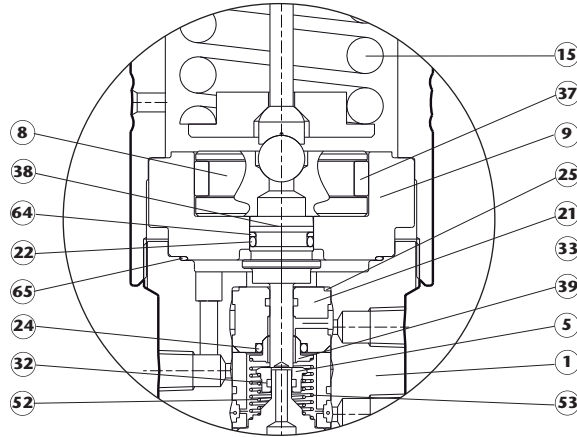

Piston design for pressures over 36 barg (522 psig)

Tag	Designation	Standard Materials	Exotic Material	
			EM1	EM6
1	Body	SS 316L	EM	EM
2	Bonnet	SS 316L	SS 316L	EM
3	Cap	SS 316L	SS 316L	EM
4	Exhaust nozzle	SS 316L	EM	EM
5	Disc	SS 316L	EM	EM
7	Feeding brace	SS 316L	EM	EM
8	Piston	SS 316L	SS 316L	EM
9	Guide	SS 316L	SS 316L	EM
10	Ball	SS or ceramic	SS or ceramic	Ceramic
11	Spindle	SS 316L	SS 316L	EM
14	Drain plug	SS 316L	EM	EM
15	Spring	Coated CS	Coated CS	Alloy X750
16	Spring washer	SS 316L	SS 316L	EM
17	Adjusting bolt	SS 316L	SS 316L	EM
18	Lock-nut	SS 316L	SS 316L	EM
19	Cap stud	SS	SS	EM
20	Nut	SS	SS	EM
21	Drain spindle O-ring	(A)	(A)	(A)
24	Seat O-ring	(A)	(A)	(A)
25	O-ring	(A)	(A)	(A)
32	Disc O-Ring	(A)	(A)	(A)
33	Brace	A 564 Gr 630 (17-4PH)		
34	Nut of drain spindle	SS	SS	EM
35	Lock washer	SS	SS	EM
36	Membrane (1)	(A)	(A)	(A)
37	Guide ring	Thermoglide™	Thermoglide™	Thermoglide™
38	Drain spindle	SS 316L	EM	EM
39	Feeding seat	A 564 Gr 630 (17-4PH)		
40	Detection piston	SS 316L	SS 316L	EM
52	Disc spring	Alloy X750	Alloy X750	Alloy X750
53	Exhaust spring	Alloy X750	Alloy X750	Alloy X750
54	Strainer	SS	EM	EM
55	Ring	Alloy 600	Alloy 600	Alloy 600
59	Bug screen	SS	SS	SS
60	Elastic ring	SS	EM	EM
61	Washer	SS 316L	EM	EM
62	Nozzle O-ring	(A)	(A)	(A)
63	Shuttle (2)	SS 316L	EM	EM
64	Backup Ring	PTFE	PTFE	PTFE
65	Body Gasket	(A)	(A)	(A)

(A) FKM (dipolymer), Steam FKM, NBR, EPDM, FFKM



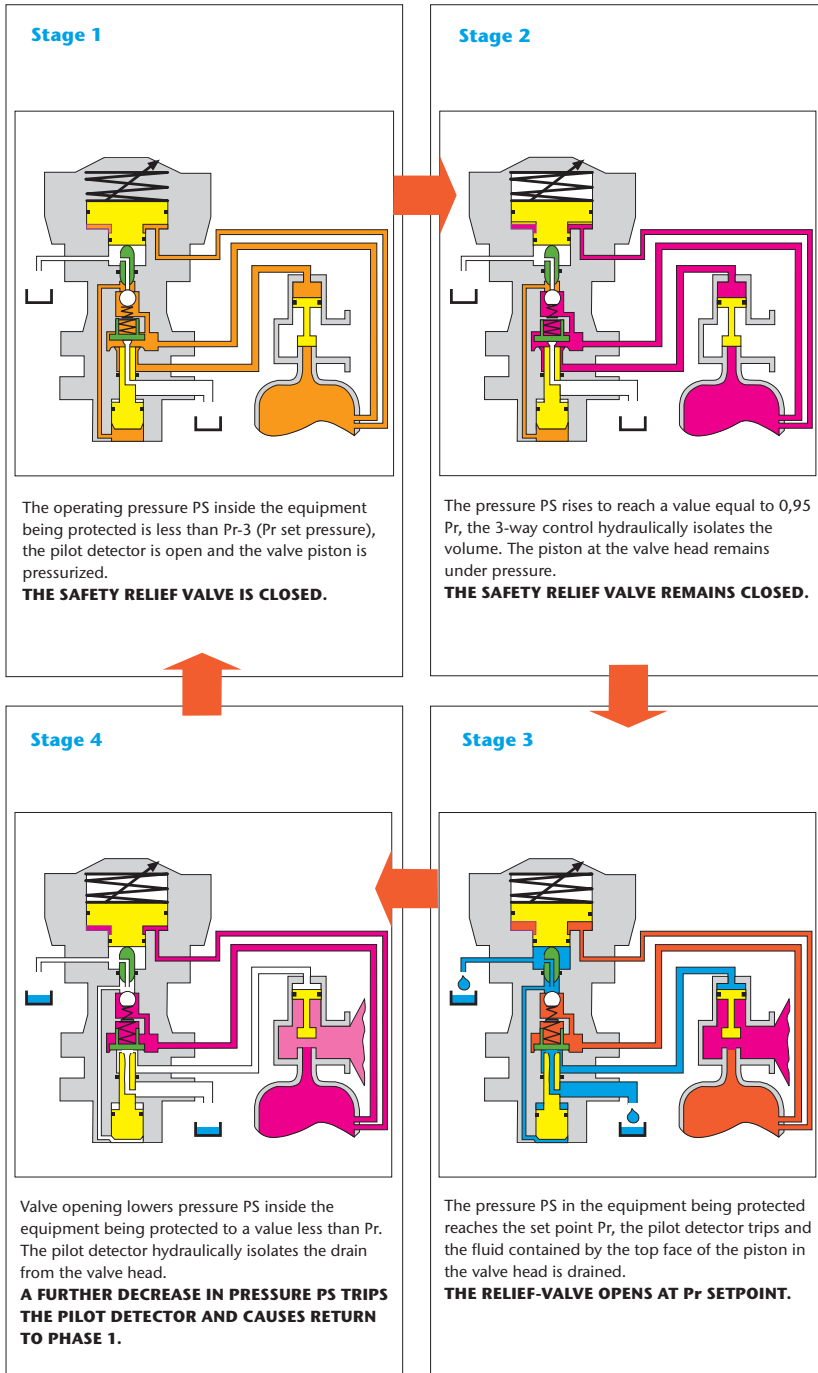

High Temperature Pilot DCM

The DCM high temperature pilot detector is a closed neutral bi-stable design. Leak tightness is achieved by the use of metallic seals throughout.

Principle

The DCM pilot detector is continuously pressurized. It combines the three key functions required of a pilot-operated safety relief valve:

- Pressure detection
- 3-way control
- 3-way power.

Features

- Minimum setting pressure : $Pr = 20 \text{ Bar (298 PSI)}$
- Temperature of the fluid in the pilot : $\text{max } T^\circ = 565^\circ\text{C (1050}^\circ\text{ F)}$
- Pressure/temperature : ASME 2500 class rating in appropriate materials
- Working pressure : $PS < 95\% Pr$
- Blowdown not adjustable $< 7\%$
- Fluid : Steam saturated or superheated
- Liquids : water (for others, please contact us)
- Natural or industrial gases (sour gas - NACE)
- Weight : 30 kg (66,2 lb)
- Size : $H = 355\text{mm (14in)}$; $\text{\O} \text{maxi} : 185\text{mm (7.3in)}$
- Integrated filters : 250u to the pilot feed and 40u 3-way control valve protection.

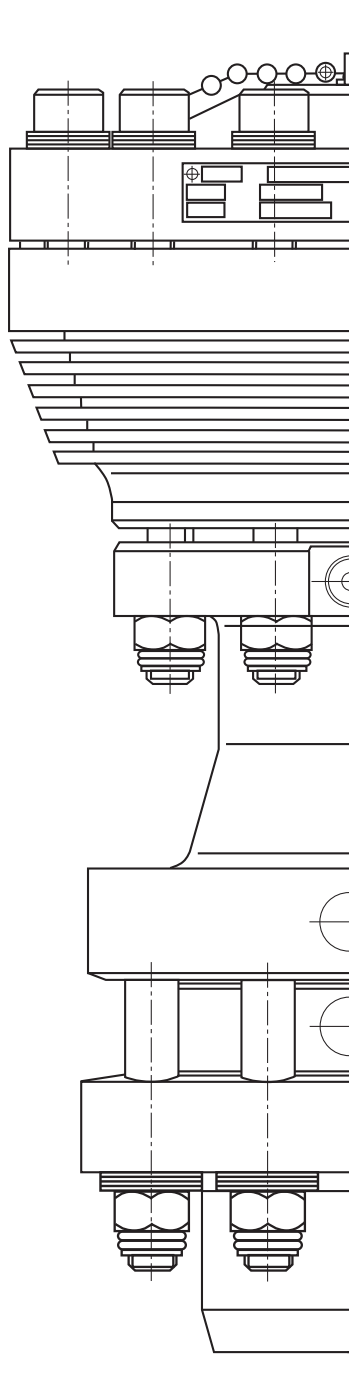

Part List	Material
Body	SS 316L
Flange	SS 316L
Head body	SS 316L
Head cover	SS 316L
3-way cartridge	Stainless steel
Power distributor	Stainless steel
Piston bellows set	Stainless steel
Detection head	Stainless steel
Spring washer	Fe15 D07
Detection head bellows set	Stainless steel
Filter	SS 316L
Metallic seal	Stainless steel/Nickel



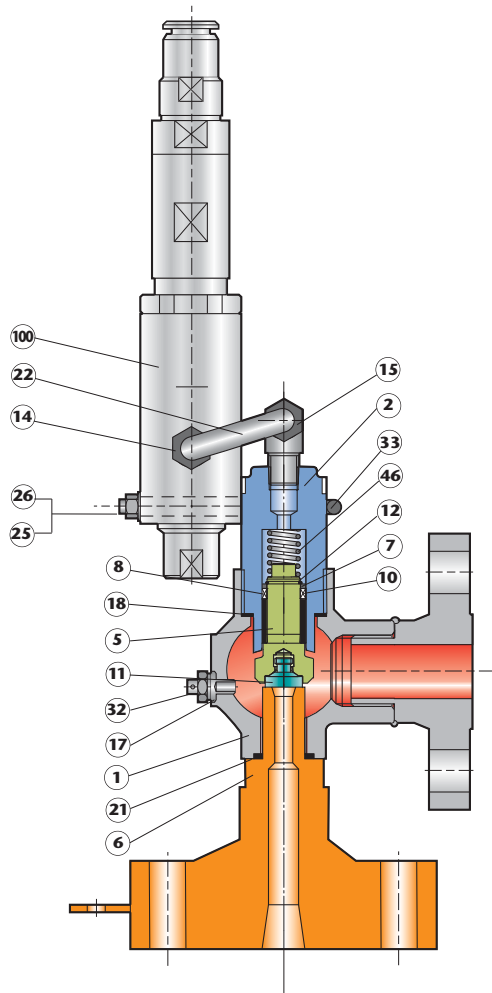

71 SERIES – Full nozzle - Portable

Materials for standard applications, very low temperature and corrosive fluids.

The 71 series is a portable pilot operated valve.

The design of 71 series is dedicated to small flow. It can also be used as discharge valve.

The 71 series is only supplied with our pop acting pilot DGS (gas only).

The dimensions A and B of the 71 series comply with the ones of our 9 series (spring loaded portable valve).

The 71 series can be supplied threaded, flanged, with welded or hub ends.

The available orifice is D (API 0.71 cm² - actual 0.801 cm²).

Tag	Designation	Standard material -29°C to +260°C Material code A	Standard material for corrosive fluid & very low temperature below -29°C Material code X
1	Body	SA 216 Gr WCC	SA 351 Gr CF3M
2	Cover	SS 316L	SS 316L
5	Piston	SS 316L	SS 316L
6	Nozzle	SS 316L	SS 316L
7	Piston Ring	SS 316L	SS 316L
8	Guide Ring	Thermoglide™	Thermoglide™
10	Piston Seal	PTFE	PTFE
11	Disc	SS 316L	SS 316L
12	Ring	SS	SS
14	Fitting	SS 316L	SS 316L
15	Dome Line Fitting	SS 316L	SS 316L
17	Plug Gasket	SS 316L	SS 316L
18	Cover Gasket	SS 316L	SS 316L
21	Nozzle Gasket	SS 316L	SS 316L
22	Dome Line	SS 316L	SS 316L
25	Nut	SS 304	SS 304
26	Washer	SS 304	SS 304
32	Plug	SS 316L	SS 316L
33	U Bolt	SS 304L	SS 304L
46	Return Spring	SS 316L	SS 316L
100	Pilot (body)	SS 316L	SS 316L

Note :

- 1. Other materials on request.
- 2. Other orifices on request.

76 SERIES – Full nozzle- API STD 526
Tables 2 to 15 dimensions

Materials for standard applications, high temperature, low temperature and corrosive fluids.

The 76 series is a versatile pressure relief valve.

The design of 76 series particularly fit together extreme conditions as Cryogenic, Liquefied Natural Gas and Steam.

The dimensions of the 76 series complies with the dimensions of the API STD 526 Table 2 to 15 (spring loaded SRV).

This valve is particularly suitable when exchanging with an API spring loaded SRV as it will fit into its dimensions and avoid costly piping modification.

Please note that if you wish to connect the sensing line on the valve inlet with a flange finish different than Raised Face (through the nozzle base thickness), the A dimension (on small PSV sizes) could deviate from API STD 526. Please consult the factory.

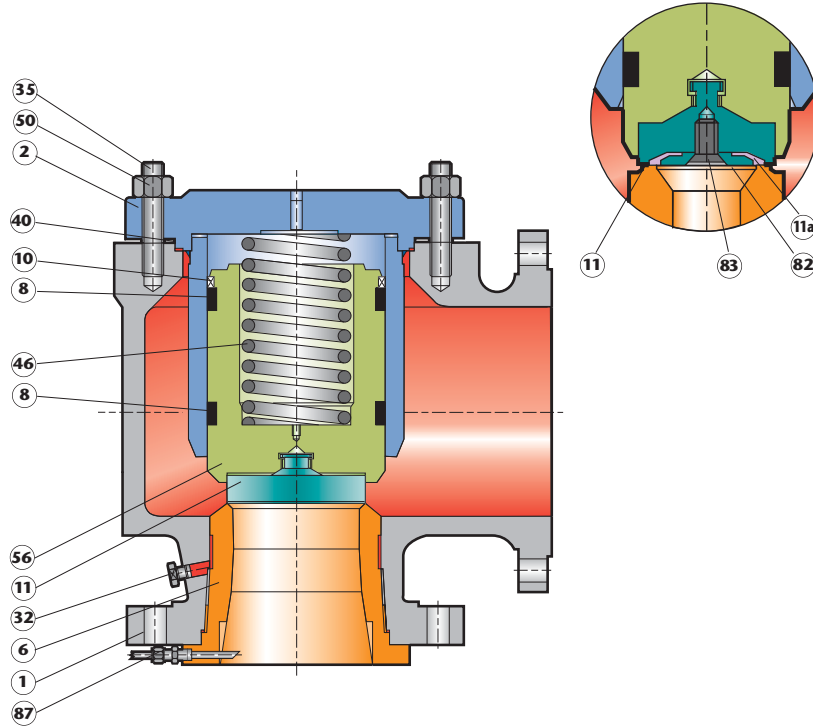

Tag	Designation	Standard material -29°C to +260°C Material Code A	Standard material low temperature -45°C to -29°C Material Code L	Standard material corrosive and very low temperature below -46°C Material Code X
1	Body	SA 216 Gr WCC	SA 352 Gr LCC	SA 351 Gr CF8M
2	Sleeve Assembly	SA 350 Gr LF2 + SS 316L	SA 350 Gr LF2 + SS 316L	SS 316L
6	Nozzle	SS 316L	SS 316L	SS 316L
8	Piston Ring	Thermoglide™	Thermoglide™	Thermoglide™
10	Piston Seal	PTFE + Graphite	PTFE + Graphite	PTFE + Graphite
11	Disc	SS 316L	SS 316L	SS 316L
11a	Soft Seat	(1)	(1)	(1)
32	Drain Plug	CS	CS	SS
35	Stud	SA 193 Gr B7	SA 193 Gr B7	SA 320 Gr B8
40	Sleeve Assembly Gasket	Klinger	Klinger	Klinger
46	Return Spring	SS	SS	SS
50	Nut	SA 194 Gr 2H	SA 194 Gr 2H	SA 194 Gr 8
56	Piston	SS 316L	SS 316L	SS 316L
82	Soft Seat Retainer	SS 316L	SS 316L	SS 316L
83	Retainer Screw	SS	SS	SS
87	Sensing Line Fitting	SS	SS	SS

Note:
 1 - FKM, NBR, EPDM, FFKM

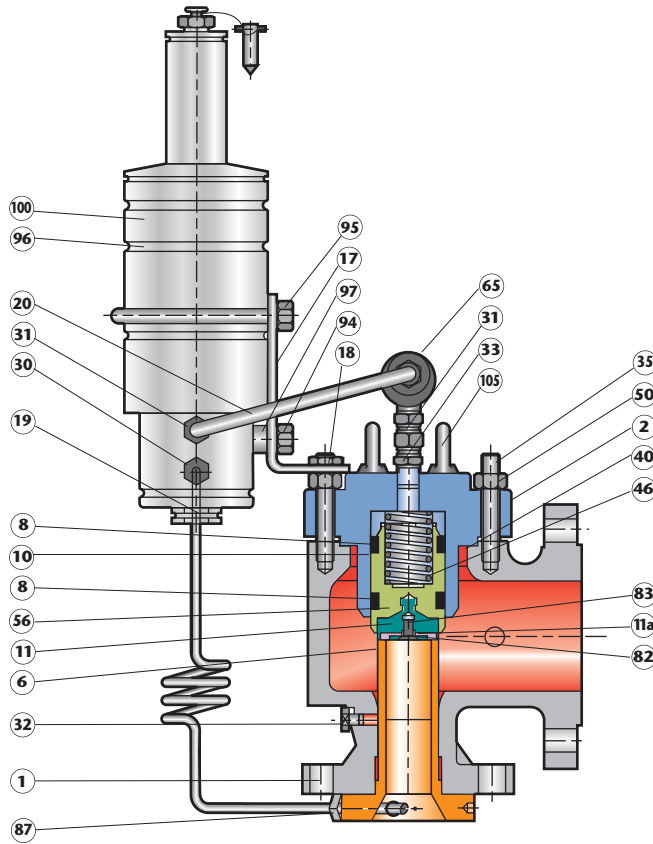

76 SERIES – Full nozzle - API STD 526
Tables 2 to 15 dimensions

Materials for Cryogenics and Liquefied Natural Gas.

Liquefied Natural Gas and more generally cryogenic applications require special features for the internal materials.

End-users and contractors must be aware that any leakage on cryogenic applications could create an ice ball around the seat and affect the pressure safety valve’s reliability.

In order to prevent any leakage due to seat damage, Sarasin-RSBD recommends the use of a soft seat.

Tag	Designation	Material for Cryogenics and LNG below -46°C Material code 10
01	Body	SA 351 Gr CF8M
02	Sleeve Assembly	SS 316L
06	Nozzle	SS 316L
08	Piston Ring	Thermoglide™
10	Piston Seal	PTFE + Graphite
11	Disc	SS 316L
11a	Soft Seat	See Soft Disc Material table
17	Bracket	SS 316L
18	Bracket Nut	SS 316L
19	Sensing Line	SS 316
20	Dome Line	SS 316
30	Inlet Pilot Fitting	SS
31	Outlet Pilot Fittings	SS
32	Drain Plug	SS
33	Line End Male Adapter	SS
35	Stud	SA 320 Gr B8
40	Cover Plate Gasket	Klinger
46	Return Spring	Alloy X750
50	Nut	SA 194 Gr 8
56	Piston	SS 316L
65	Backflow Preventer	SS 316L
82	Soft Seat Retainer	SS 316L
83	Retainer Screw	SS
87	Sensing Line Fitting	SS
94	Bracket Screw	SS 316L
95	Bracket Nut	SS 316L
96	Strap	SS 316L
97	Strut	SS 316L
100	Pilot (body)	SS 316L
105	Lifting Eye Bolt	CS

Soft Seat Material

Set Pressure (barg)	Seat Material
1 < SP < A	PTFE
A < SP < B	PCTFE
B < SP < C	PEEK

A, B and C: demands on the size of the valve - please consult factory

**76 SERIES – Full nozzle - API STD 526
Tables 2 to 15 dimensions**

Corrosive and sour gas service

Many process streams in the oil and gas industry contain enough H₂S to cause sulfide stress cracking (SSC) in susceptible materials. It exists in two different domains in which two different standards may be applicable:

- Oil and Gas production: NACE MR0175/ISO 15156
 - Part 1 - 2001 : General principles for selection of cracking-resistant materials
 - Part 2 - 2003 : Cracking-resistant carbon and low alloy steels, and the use of cast irons.
 - Part 3 - 2003 : Cracking-resistant CRAs (corrosion-resistant alloys) and other alloys.
- Oil and gas refining: NACE MR0103

The last revisions of NACE MR0175/ISO 15156 shows results of the inadequacy of some standard materials commonly used in the oil and gas industry. We then highlight this point and ask the end-user to clearly specify the conditions of use (fluid details, pressure and temperature) in order to be able to select acceptable materials.

Weir Power & Industrial France manufactures a large variety of valves used in sour service. Based on our experience and the last edition of the standards, the definition of the actual critical components in a pressure safety valve should be mutually agreed between the purchaser and Weir Power & Industrial.

Please note, materials are applicable for NACE MR0175/ISO 15156 according to the different paragraphs of the standard. As a first approach, we can note the following:

Materials	Paragraph
SA 352 Gr LCC	MR0175/ISO 15156-2 ¶ A2-1-2
SA 216 Gr WCC	MR0175/ISO 15156-2 ¶ A2-1-2
SA 217 Gr WC6	MR0175/ISO 15156-2 ¶ A2-1-2
SA 479 Gr 316L	MR0175 ISO 15156-3 ¶ A2-2 Table 2
UNS S31803	MR0175/ISO 15156-3 ¶ A7-2 Table 24
UNS N06625	MR0175/ISO 15156-3 ¶ A4-2 Table 13
UNS N07750	MR0175/ISO 15156-3 ¶ A2-9 Table 36

As an example of selection, Weir Power and Industrial can advise the following valve configuration. The conditions here are not so restrictive: temperature limited to 149°C (300°F).

SGA application : applicable on primary side only

Part N°	Part Name	Material	Applicable Paragraph
1	Body	SA 216 Gr WCC	MR0175/ISO 15156-2 ¶ A2-1-2
3	Nozzle	UNS S31803 (Duplex)	MR0175/ISO 15156-3 ¶ A7-2 Table A24
4	Disc	UNS S31803 (Duplex)	MR0175/ISO 15156-3 ¶ A7-2 Table A24
2	Sleeve Assembly	UNS S31803 (Duplex)	MR0175/ISO 15156-3 ¶ A7-2 Table A24
5	Piston	SA 479 Gr 316L	MR0175/ISO 15156-3 ¶ 1 Table A1
14	Spring	Alloy X750	
	Other parts	Standard	

SGB application : applicable on primary and secondary sides

Part N°	Part Name	Material	Applicable Paragraph
1	Body	SA 216 Gr WCC	MR0175/ISO 15156-2 ¶ A2-1-2
3	Nozzle	UNS S31803 (Duplex)	MR0175/ISO 15156-3 ¶ A7-2 Table A24
4	Disc	UNS S31803 (Duplex)	MR0175/ISO 15156-3 ¶ A7-2 Table A24
2	Sleeve Assembly	UNS S31803 (Duplex)	MR0175/ISO 15156-3 ¶ A7-2 Table A24
5	Piston	SA 479 Gr 316L	MR0175/ISO 15156-3 ¶ 1 Table A1
14	Spring	Alloy X750	
	Other parts	Standard	

Note : Above 233°C (500°F), parts 2-3-4 will be proposed in UNS N06625 (Alloy 625).

76 SERIES – Full nozzle- API STD 526
Tables 2 to 15 dimensions

DUPLEX

Application : corrosive fluid and offshore

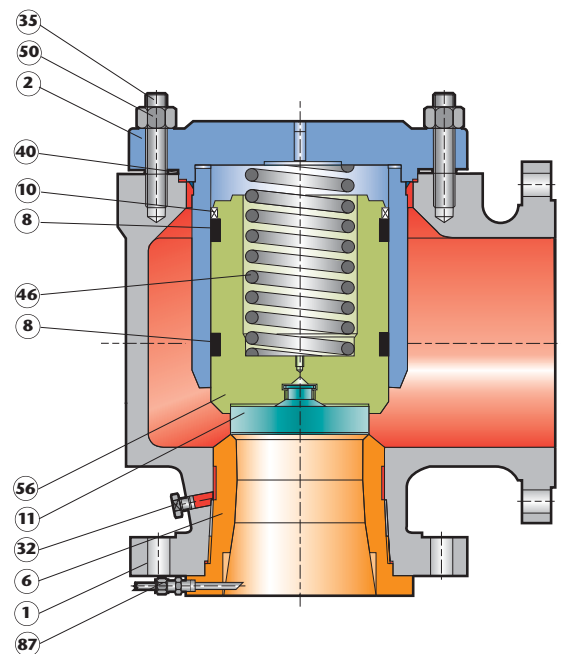

Part N°	Part Name	Material code D1	Material code D6
1	Body	SA 216 Gr WCC	Duplex (1)
2	Sleeve Assembly	SA 350 Gr LF2 + SS 316L	Duplex (1)
6	Nozzle	Duplex	Duplex (1)
8	Piston Ring	Thermoglide™	Thermoglide™
10	Piston Seal	PTFE + Graphite	PTFE + Graphite
11	Disc	Duplex	Duplex (1)
32	Drain Plug	CS	Duplex (1)
35	Stud	SA 193 Gr B7	Duplex (1)
40	Sleeve Assembly Gasket	Klinger	
46	Return Spring	SS	Alloy X750
50	Nut	SA 194 Gr 2H	Duplex (1)
56	Piston	SS 316L	Duplex (1)
87	Sensing Line Fitting	SS	SS

Note : 1 – Duplex standard (22%) UNS 31803, superduplex (25%) UNS 32750 or 32760 on request

76 SERIES – Full nozzle- API STD 526 Tables 2 to 15 dimensions

Pressure limits (1)

barg (psig)	Gas/Liquid		Steam		
	Pop (DGS)	Modulating (DCS)	DCS		
			Standard configuration	Special configuration without Heat Exchanger	Special configuration incl. Heat Exchanger
Minimum	1.8 (26.1)	2 (29)	2.3 (33.4)	2.3 (33.4)	2.3 (33.4)
Maximum	431 (6250)	431 (6250)	25 (363)	79 (1145)	150 (2175)

Temperature limits (1)

°C (°F)	Gas/Liquid				Steam		
	Pop (DGS)		Modulating (DCS)		DCS		
	Standard configuration	Special configuration	Standard configuration	Special configuration	Standard configuration	Special configuration without Heat Exchanger	Special configuration incl. Heat Exchanger
Minimum	-50 (-58)	-196 (-321)	-50 (-58)	-196 (-321)	-	-	-
Maximum	230 (446)	310 (590)	230 (446)	345 (653)	230 (446)	295 (563)	600 (1112)

- Note:**
- 1 - For pressures and temperatures above these limits, please consult factory.
 - 2 - Temperature limit at pilot inlet
 - 3 - Temperature limit at temperature sense location
 - 4 - The temperature and pressure limits depend on the soft good nature. Please contact the factory for details.

Options/Configurations/Applications

Options	Pop (DGS)	Modulating (DCS)
Pilot Vented to Body Bowl	No	Yes
Remote Pressure Sensing	Yes	Yes
Pilot Supply Filter	Yes	Yes
Heat Exchanger	Yes	Yes
Back Flow Preventer	Yes	Yes
Manual Blowdown Valve	Yes	Yes
Separate Feeding (dirty service)	No	Yes
Field Test Connection	Yes	Yes
Pilot Lift Lever	Yes	Yes
Remote Unloader (remote opening)	Yes	Yes
Dual Filter	Yes	Yes
Dual Pilot	Yes	Yes
Pressure Differential Switch	Yes	Yes
Configurations		
Pop action	Yes	No
Modulating action	No	Yes
Non-flowing	Yes	Yes
Blowdown	2% to 5%	2% to 5%
Seat Tightness before opening (% of Set Pr.)	95%	98%
Back Pressure limits		
with pilot vented to atmosphere	97%	97%
with pilot vented to body bowl		
Constant	0	Depends on set pressure level – Consult factory
Variable	0	
Applications		
Gas	Yes	Yes
Liquid	No	Yes
Steam	No	Yes
Liquefied Natural Gas	No	Yes
Cryogenic	No	Yes
Water Hammer Reduction	No	Yes
Pumping system	No	Yes

76 SERIES – Full nozzle- API STD 526 Tables 2 to 15 dimensions

Discharge coefficient

K (ASME Section VIII div. 1/ISO 4126)		KD (API STD 520)	
Gas, Vapor, Steam	Liquid	Gas, Vapor, Steam	Liquid
0.848		0.975	0.65

Pressure/Temperature Rating Table (barg / °C)

SA 216 Grade WCC							SA 351 Grade CF8M						
Temperature from -29°C	150	300	600	900	1500	2500	Temperature from -196°C	150	300	600	900	1500	2500
38	19.8	51.7	103.4	155.1	258.6	430.9	38	19	49.6	99.3	148.9	248.2	413.7
50	19.5	51.7	103.4	155.1	258.6	430.9	50	18.4	48.1	96.2	144.3	240.6	400.9
100	17.7	51.5	103	154.6	257.6	429.4	100	16.2	42.2	84.4	126.6	211	351.6
150	15.8	50.2	100.3	150.5	250.8	418.1	150	14.8	38.5	77	115.5	199.5	320.8
200	13.8	48.6	97.2	145.8	243.2	405.4	200	13.7	35.7	71.3	107	178.3	297.2
250	12.1	46.3	92.7	139	231.8	386.2	250	12.1	33.4	66.8	100.1	166.9	278.1
300	10.2	42.9	85.7	128.6	214.4	357.1	300	10.2	31.6	63.2	94.9	158.1	263.5
310	9.8	42.3	84.5	126.8	211.3	352	310	9.8	31.3	62.6	94	154.4	256.6

Note: 1 - For pressures and temperatures above these limits, please consult factory.

76 SERIES - Full nozzle - API STD 526 Tables 2 to 15 dimensions

Orifices Tables - Inlet x Outlet combinations according API STD 526 6Th Ed. 2009 (spring loaded SRV tables)

POSRV 76 series										
Actual	in ²	0.124	0.222	0.352	0.568	FLANGE RATING ASME B 16.5				
	cm ²	0.800	1.432	2.271	3.665					
API	in ²	0.110	0.196	0.307	0.503	FLANGE RATING ASME B 16.5				
	cm ²	0.710	1.265	1.981	3.245					
Orifice		D	E	F	G					
Size	I	O	I	O	I	O	I	O	I	O
	150	1	2	1	2	1.5	2	1.5	3	150
1		2	1	2	1.5	2	1.5	3	300L	
1		2	1	2	1.5	2	1.5	3	300	
1		2	1	2	1.5	2	1.5	3	600	
300	1.5	2	1.5	2	1.5	3	1.5	3	900	300
	1.5	2	1.5	2	1.5	3	2	3	1500	
	1.5	3	1.5	3	1.5	3	2	3	2500	

POSRV 76 series																												
Actual	in ²	0.887	1.457	2.097	3.232	4.065	5.143	7.069	12.915	15.900	22.190	28.274	39.440	46.750	61.630	Flange Rating ASME B 16.5												
	cm ²	5.723	9.400	13.529	20.852	26.226	33.181	45.606	83.322	102.580	143.161	182.413	254.451	301.612	397.612													
API	in ²	0.785	1.287	1.838	2.853	3.600	4.340	6.380	11.050	16.000		26.000				Flange Rating ASME B 16.5												
	cm ²	5.065	8.303	11.858	18.406	23.226	28.000	41.161	71.290	103.226		167.742																
Orifice		H	J	K	L	M	N	P	Q	R	S	T	U	V**	W													
Size	I	O	I	O	I	O	I	O	I	O	I	O	I	O	I	O	I	O	I	O								
	150	1.5	3	2	3	3	4	3	4	4	6	4	6	4	6	8	6	8	8	10	8	10	10	14	10	14	12	2x12
1.5		3	2	3	3	4	3	4	4	6	4	6	4	6	8	6	8	8	10	8	10	8	10	10	14	-	-	300L
2		3	3	4	3	4	4	6	4	6	4	6	4	6	8	6	8	6	10	8	10	8	10	-	-	10	14	300
2		3	3	4	3	4	4	6	4	6	4	6	4	6	8	6	8	6	10	-	-	-	-	-	-	-	-	600
2		3	3	4	3	6	4	6	4	6	4	6	4	6	-	-	-	-	-	-	-	-	-	-	-	-	-	900
2		3	3	4	3	6	4	6*	-	-	-	-	-	-	-	-	-	-	-	-	-	-	-	-	-	-	-	1500

Note: Inlet and outlet size combinations as well as orifice sizes shown in the table above are compliant with API Standard 526 - Fifth Edition, 2002
 * Supplied with a 150# outlet flange ** V orifice not 'UV' stampable on 76 series (body and orifice of Starflow series)

For replacement (former edition of API STD 526 or special light design) - consult factory if still topical production
Orifices Tables - Inlet x Outlet combinations according API STD 526 - 1995 and before

POSRV 76 series										
Actual	in ²	0.124	0.222	0.352	0.568	FLANGE RATING ASME B 16.5				
	cm ²	0.800	1.432	2.271	3.665					
API	in ²	0.110	0.196	0.307	0.503	FLANGE RATING ASME B 16.5				
	cm ²	0.710	1.265	1.981	3.245					
Orifice		D	E	F	G					
Size	I	O	I	O	I	O	I	O	I	O
	150	-	-	-	-	1	2	1.5	2.5	150
-		-	-	-	1	2	1.5	2.5	300	
-		-	-	-	1	2	1.5	2.5	300	
-		-	-	-	1	2	1.5	2.5	600	
300	-	-	-	-	1.5	2	1.5	2.5	900	300
	-	-	-	-	1.5	2	1.5	2.5	1500	
	1.5	2.5	1.5	2.5	1.5	2.5	1.5	2.5	2500	

POSRV 76 series																					
Actual	in ²	0.887	1.457	2.097	3.232	4.065	5.143	7.069	12.915	15.900	22.190	28.274	39.440	46.750	61.630	Flange Rating ASME B 16.5					
	cm ²	5.723	9.400	13.529	20.852	26.226	33.181	45.606	83.322	102.580	143.161	182.413	254.451	301.612	397.612						
API	in ²	0.785	1.287	1.838	2.853	3.600	4.340	6.380	11.050	16.000		26.000				Flange Rating ASME B 16.5					
	cm ²	5.065	8.303	11.858	18.406	23.226	28.000	41.161	71.290	103.226		167.742									
Orifice		H	J	K	L	M	N	P	Q	R	S	T	U	V	W						
Size	I	O	I	O	I	O	I	O	I	O	I	O	I	O	I	O	I	O	I	O	
	150	1.5	2.5	1.5	3	-	-	-	-	3*	4*	3***	4***	4*	6*	-	-	-	-	-	-
1.5		2.5	1.5	3	-	-	-	-	3*	4*	3***	4***	4*	6*	-	-	-	-	-	-	300L
1.5		2.5	2*	3*	2.5	4	-	-	4*	6*	4***	6***	4*	6*	-	-	-	-	-	-	300
-		-	2.5	4	-	-	-	-	-	-	-	-	-	-	-	-	-	-	-	-	-
1.5		2.5	2*	3*	2.5	4	-	-	-	4***	6***	4*	6*	-	6*	8*	-	-	-	-	600
-		-	2.5	4	-	-	-	-	-	-	-	-	-	-	-	-	-	-	-	-	-
1.5		2.5	2*	3*	3*	4*	3*	6*	3**	6**	4***	6***	4*	6*	-	-	-	-	-	-	900
2		3	2*	3*	3*	4*	3*	6*	3**	6**	4***	6***	-	-	-	-	-	-	-	-	1500
2		3	-	-	-	-	-	-	-	-	-	-	-	-	-	-	-	-	-	-	2500

Note: * Body size is the API STD 526 one of the previous orifice letter ** Body size is the one of K orifice *** Body size is the one of L orifice

76 Series - Full nozzle - API STD 526 Tables 2 to 15 dimensions

Dimensions and Weights

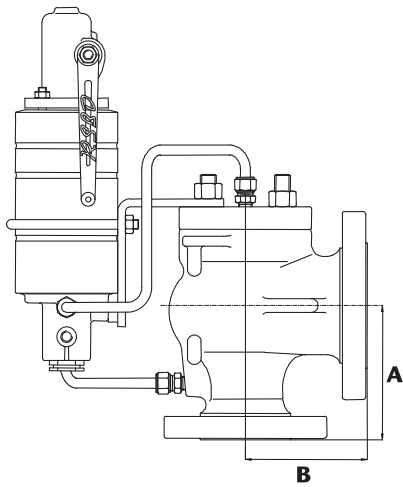
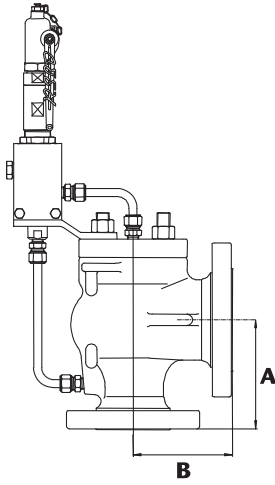

Size and Orifice (inch and API letter)			Flange rating (ASME B16.5)		Dimensions (mm)		Approx. Weight (kg)
Inlet	Orifice	Outlet	Inlet	Outlet	A	B	
1	D	2	150	150	104.78	114.3	27
1	D	2	300	150	104.78	114.3	27
1	D	2	300	150	104.78	114.3	27
1	D	2	600	150	104.78	114.3	27
1.5	D	2	900	300	104.78	139.7	40
1.5	D	2	1500	300	104.78	139.7	40
1.5	D	3	2500	300	139.7	177.8	45
1	E	2	150	150	104.78	114.3	27
1	E	2	300	150	104.78	114.3	27
1	E	2	300	150	104.78	114.3	27
1	E	2	600	150	104.78	114.3	27
1.5	E	2	900	300	104.78	139.7	40
1.5	E	2	1500	300	104.78	139.7	40
1.5	E	3	2500	300	139.7	177.8	45
1.5	F	2	150	150	123.83	120.65	33
1.5	F	2	300	150	123.83	120.65	33
1.5	F	2	300	150	123.83	152.4	33
1.5	F	2	600	150	123.83	152.4	34
1.5	F	3	900	300	123.83	165.1	35
1.5	F	3	1500	300	123.83	165.1	35
1.5	F	3	2500	300	139.7	177.8	37
1.5	G	3	150	150	123.83	120.65	33
1.5	G	3	300	150	123.83	120.65	33
1.5	G	3	300	150	123.83	152.4	35
1.5	G	3	600	150	123.83	152.4	36
1.5	G	3	900	300	123.83	165.1	45
2	G	3	1500	300	155.58	171.45	55
2	G	3	2500	300	155.58	171.45	55
1.5	H	3	150	150	130.18	123.83	35
1.5	H	3	300	150	130.18	123.83	36
2	H	3	300	150	130.18	123.83	36
2	H	3	600	150	153.99	162.18	40
2	H	3	900	150	153.99	162.18	55
2	H	3	1500	300	153.99	162.18	56
2	J	3	150	150	136.78	123.83	37
2	J	3	300	150	136.78	123.83	37
3	J	4	300	150	184.15	180.98	50
3	J	4	600	150	184.15	180.98	56
3	J	4	900	150	184.15	180.98	81
3	J	4	1500	300	184.15	180.98	82
3	K	4	150	150	155.58	162.18	50
3	K	4	300	150	155.58	162.18	51
3	K	4	300	150	155.58	162.18	52
3	K	4	600	150	184.15	180.98	59
3	K	6	900	150	198.43	215.9	87
3	K	6	1500	300	196.85	215.9	97

Note: If you wish to connect the sensing line on the valve inlet with a flange finish different than Raised Face (through the nozzle base thickness), the A dimension (on small PSV sizes) could deviate from API STD 526. Please consult the factory.

76 Series - Full nozzle - API STD 526 Tables 2 to 15 dimensions

Dimensions and Weights

Size and Orifice (inch and API letter)			Flange rating (ASME B16.5)		Dimensions (mm)		Approx. Weight (kg)
Inlet	Orifice	Outlet	Inlet	Outlet	A	B	
3	L	4	150	150	155.58	165.1	51
3	L	4	300	150	155.58	165.1	55
4	L	6	300	150	179.39	180.98	100
4	L	6	600	150	179.39	203.2	105
4	L	6	900	150	196.85	222.25	115
4	L	6	1500	150	196.85	222.25	118
4	M	6	150	150	177.8	184.15	75
4	M	6	300	150	177.8	184.15	75
4	M	6	300	150	177.8	184.15	90
4	M	6	600	150	177.8	203.2	105
4	M	6	900	150	196.85	222.25	120
4	N	6	150	150	196.85	209.55	94
4	N	6	300	150	196.85	209.55	105
4	N	6	300	150	196.85	209.55	110
4	N	6	600	150	196.85	222.25	115
4	N	6	900	150	196.85	222.25	155
4	P	6	150	150	180.98	228.6	95
4	P	6	300	150	180.98	228.6	95
4	P	6	300	150	225.43	254	115
4	P	6	600	150	225.43	254	120
4	P	6	900	150	225.43	254	180
6	Q	8	150	150	239.71	241.3	170
6	Q	8	300	150	239.71	241.3	170
6	Q	8	300	150	239.71	241.3	180
6	Q	8	600	150	239.71	241.3	215
6	R	8	150	150	239.71	241.3	185
6	R	8	300	150	239.71	241.3	185
6	R	10	300	150	239.71	266.7	220
6	R	10	600	150	239.71	266.7	250
8	S	10	150	150	276.23	279.4	225
8	S	10	300	150	276.23	279.4	240
8	T	10	150	150	276.23	279.4	255
8	T	10	300	150	276.23	279.4	260
10	U	14	150	150	379.41	369.89	330
10	U	14	300	150	379.41	369.89	330
10	V	14	150	150	379.41	369.89	330
10	V	14	300	150	379.41	369.89	330
12	W	2x12	150	150	328.61	430.21	570

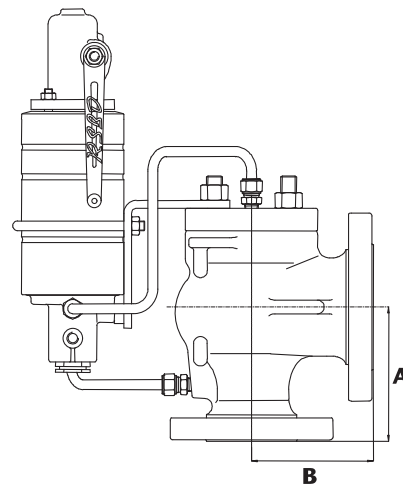
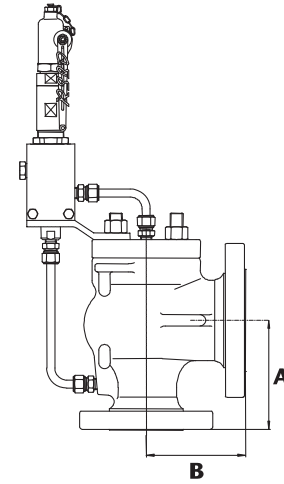

Note: If you wish to connect the sensing line on the valve inlet with a flange finish different than Raised Face (through the nozzle base thickness), the A dimension (on small PSV sizes) could deviate from API STD 526. Please consult the factory.

78 Series - Semi nozzle - API STD 526

Materials for standard applications, high temperature, low temperature and corrosive fluids.

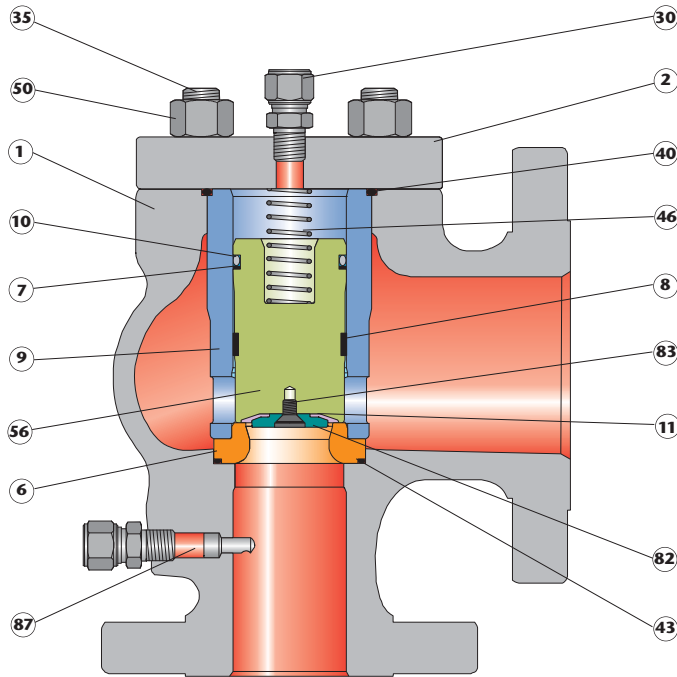

The 78 series is a versatile pressure relief valve.

The design of 78 series makes it particularly suitable for use in general oil and gas processes as well as extreme services such as offshore.

The dimensions of the 78 series comply with the dimensions of the API STD 526 Tables 16 to 29.

The nozzle has been designed to have the best flow coefficient possible.

Tag	Designation	Standard material -29 °C to +260 °C Material code W	Standard material -45 °C to -29 °C Material code L	Standard material Corrosive & very low temperatures below -46 °C Material code X
1	Body	SA 216 Gr WCC	SA 352 Gr LCC	SA 351 Gr CF8M
2	Cover	SS 316L	SS 316L	SS 316L
6	Seat	SS 316L	SS 316L	SS 316L
7	Back up ring (1)	PTFE	PTFE	PTFE
8	Guide Ring	PTFE + Graphite	PTFE + Graphite	PTFE + Graphite
9	Guide	SS 316L	SS 316L	SS 316L
10	Piston O-Ring	(B)	(B)	(B)
11	Soft Seat	(A)	(A)	(A)
30	Fitting	Carbon St./Stainless St.	Carbon St./Stainless St.	SS 316L
35	Stud	SA 193 Gr B7	SA 193 Gr B7	SA 193 Gr B8
40	O-ring	(B)	(B)	(B)
43	Seat O-Ring	(C)	(C)	(C)
46	Return Spring (1)	Stainless Steel	Stainless Steel	Stainless Steel
50	Nut	SA 194 Gr 2H	SA 194 Gr 4	SA 194 Gr 8
56	Piston	SS 316L	SS 316L	SS 316L
82	Retainer Washer	SS 316L	SS 316L	SS 316L
83	Retainer Screw	Stainless Steel	Stainless Steel	Stainless Steel
87	Sensing Line Fitting	SS 316L	SS 316L	SS 316L
	Bracket	Carbon Steel	Carbon Steel	Stainless Steel
	Sensing Line	SS 316L	SS 316L	SS 316L

(1) Depending on pressure
 (A) FKM, NBR, EPDM, PTFE
 (B) FKM, NBR, EPDM, FFKM

78 SERIES – Semi nozzle - API STD 526

Corrosive and sour gas service

Many process streams in oil and gas industry contain enough H₂S to cause sulfide stress cracking (SSC) in susceptible materials. It exists in two different domains in which two different standards may be applicable:

- Oil and Gas production: NACE MR0175/ISO 15156
 - Part 1 - 2001 : General principles for selection of cracking-resistant materials
 - Part 2 - 2003 : Cracking-resistant carbon and low alloy steels, and the use of cast irons.
 - Part 3 - 2003 : Cracking-resistant CRAs (corrosion-resistant alloys) and other alloys.
- Oil and gas refining: NACE MR0103

The last revisions of NACE MR0175/ISO 15156 shows results of the inadequacy of some standard materials commonly used in the oil and gas industry. We then highlight this point and ask the end-user to clearly specify the conditions of use (fluid details, pressure and temperature) in order to be able to select acceptable materials.

Weir Power & Industrial France manufactures a large variety of valves used in sour service. Based on our experience and the last edition of the standards, the definition of the actual critical components in a pressure safety valve should be mutually agreed between the purchaser and Weir Power & Industrial.

Please note, materials are applicable for NACE MR0175/ISO 15156 according to the different paragraphs of the standard. As a first approach, we can note the following:

Materials	Paragraph
SA 352 Gr LCC	MR0175/ISO 15156-2 ¶ A2-1-2
SA 216 Gr WCC	MR0175/ISO 15156-2 ¶ A2-1-2
SA 217 Gr WC6	MR0175/ISO 15156-2 ¶ A2-1-2
SA 479 Gr 316L	MR0175/ISO 15156-3 ¶ A2-2 Table 2
UNS S31803	MR0175/ISO 15156-3 ¶ A7-2 Table 24
UNS N06625	MR0175/ISO 15156-3 ¶ A4-2 Table 13
UNS N07750	MR0175/ISO 15156-3 ¶ A2-9 Table 36

As an example of selection, Weir Power and Industrial can advise the following valve configuration. The conditions here are not so restrictive: temperature limited to 149°C (300°F).

SGA application : applicable on primary side only

Part N°	Part Name	Material	Applicable Paragraph
1	Body	SA 216 Gr WCC	MR0175/ISO 15156-2 ¶ A2-1-2
2	Cover	UNS S31803 (Duplex)	MR0175/ISO 15156-3 ¶ A7-2 Table A24
3	Nozzle	UNS S31803 (Duplex)	MR0175/ISO 15156-3 ¶ A7-2 Table A24
4	Disc (metal seat)	UNS S31803 (Duplex)	MR0175/ISO 15156-3 ¶ A7-2 Table A24
5	Piston	SA 479 Gr 316L	MR0175/ISO 15156-3 ¶ 1 Table A1
9	Guide	UNS S31803 (Duplex)	MR0175/ISO 15156-3 ¶ A7-2 Table A24
14	Spring	Alloy X750	
	Other parts	Standard	

SGB application : applicable on primary and secondary sides

Part N°	Part Name	Material	Applicable Paragraph
1	Body	SA 216 Gr WCC	MR0175/ISO 15156-2 ¶ A2-1-2
2	Cover	UNS S31803 (Duplex)	MR0175/ISO 15156-3 ¶ A7-2 Table A24
3	Nozzle	UNS S31803 (Duplex)	MR0175/ISO 15156-3 ¶ A7-2 Table A24
4	Disc (metal seat)	UNS S31803 (Duplex)	MR0175/ISO 15156-3 ¶ A7-2 Table A24
5	Piston	SA 479 Gr 316L	MR0175/ISO 15156-3 ¶ 1 Table A1
9	Guide	UNS S31803 (Duplex)	MR0175/ISO 15156-3 ¶ A7-2 Table A24
14	Spring	Alloy X750	
	Other parts	Standard	

Note : Above 233°C (500°F), parts 2-3-4 will be proposed in UNS N06625 (Alloy 625).

78 SERIES – Semi nozzle - API STD 526**DUPLEX**

Application : corrosive fluid and offshore

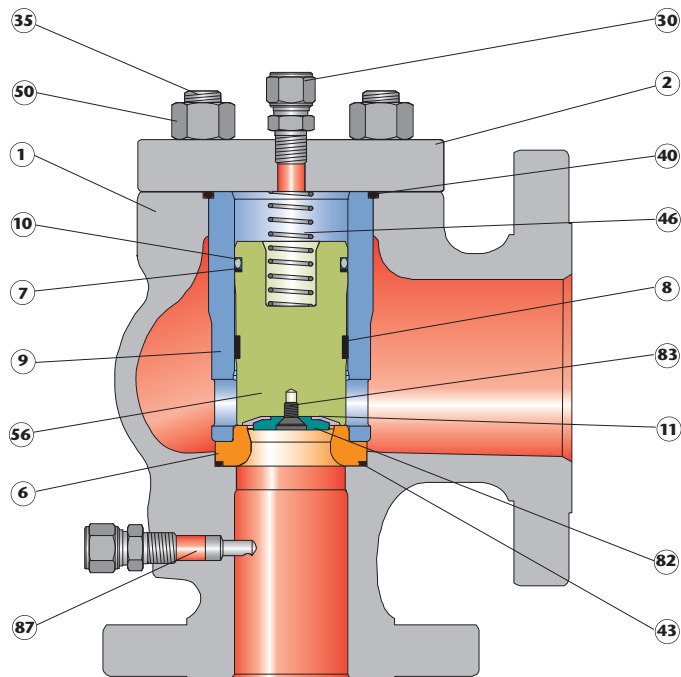

Part N°	Part Name	Material code D6
1	Body	Duplex (1)
2	Cover	Duplex (1)
6	Nozzle	Duplex (1)
7	Back-up Ring	PTFE
8	Guide Ring	PTFE + Graphite
9	Guide	Duplex (1)
10	Piston O'ring	(2)
11	Soft Seat	(2)
30	Fitting	
35	Stud	Duplex (1)
40	O'ring	(2)
43	Seat O'ring	(2)
46	Return Spring	Alloy X750
50	Nut	Duplex (1)
56	Piston	Duplex (1)
82	Retainer Washer	Duplex (1)
83	Retainer Screw	Duplex (1)
87	Sensor (sensing line)	SS

Note :

1 – Duplex standard (22%) UNS 31803, superduplex (25%) UNS 32750 or 32760 on request
 2 – FKM, NBR, EPDM, FFKM

78 SERIES – Semi nozzle - API STD 526

Pressure limits (1)

barg (psig)	Gas/Liquid		Steam
	Pop (DGS)	Modulating (DCS)	DCS
Minimum	1.8 (26.1)	2 (29)	2.3 (33.4)
Maximum	431 (6250)	431 (6250)	39 (565)

Temperature limits (1)

°C (°F)	Gas/Liquid				Steam	
	Pop (DGS)		Modulating (DCS)		DCS	
	Standard Configuration	Special Configuration	Standard Configuration	Special Configuration	Standard Configuration	Special Configuration
Minimum	-50 (-58)	-50 (-58)	-50 (-58)	-50 (-58)	-	-
Maximum	230 (446)	260 (500)	230 (446)	260 (500)	200 (392)	250 (482)

- Note:**
- 1 - For pressures and temperatures above these limits, please consult factory.
 - 2 - Temperature limit at pilot inlet
 - 3 - Temperature limit at temperature sense location
 - 4 - The temperature and pressure limits depend on the soft good nature. Please contact the factory for details.

Options/Configurations/Applications

Options	Pop (DGS)	Modulating (DCS)
Pilot Vented to Body Bowl	No	Yes
Remote Pressure Sensing	Yes	Yes
Pilot Supply Filter	Yes	Yes
Heat Exchanger	Yes	Yes
Back Flow Preventer	Yes	Yes
Manual Blowdown Valve	Yes	Yes
Separate Feeding (dirty service)	No	Yes
Field Test Connection	Yes	Yes
Pilot Lift Lever	Yes	Yes
Remote Unloader (remote opening)	Yes	Yes
Dual Filter	Yes	Yes
Dual Pilot	Yes	Yes
Pressure Differential Switch	Yes	Yes
Configurations		
Pop action	Yes	No
Modulating action	No	Yes
Non-flowing	Yes	Yes
Blowdown	2% to 5%	2% to 5%
Seat Tightness before opening (% of Set Pr.)	95%	98%
Back Pressure limits		
with pilot vented to atmosphere	97%	97%
with pilot vented to body bowl		
Constant	0	Depends on set pressure level –
Variable	0	Consult factory
Applications		
Gas	Yes	Yes
Liquid	No	Yes
Steam	No	Yes
Liquefied Natural Gas	No	No
Cryogenic	No	No
Water Hammer Reduction	No	Yes
Pumping system	No	Yes

78 SERIES – Semi nozzle - API STD 526

Discharge coefficient

K (ASME Section VIII div. 1/ISO 4126)		K _D (API STD 520)	
Gas, Vapor, Steam	Liquid	Gas, Vapor, Steam	Liquid

Pressure/Temperature Rating Table (barg/°C)

Temperature from -29°C	SA 216 Grade WCC						Temperature from -196°C	SA 351 Grade CF8M					
	150	300	600	900	1500	2500		150	300	600	900	1500	2500
38	19.8	51.7	103.4	155.1	258.6	430.9	38	19	49.6	99.3	148.9	248.2	413.7
50	19.5	51.7	103.4	155.1	258.6	430.9	50	18.4	48.1	96.2	144.3	240.6	400.9
100	17.7	51.5	103	154.6	257.6	429.4	100	16.2	42.2	84.4	126.6	211	351.6
150	15.8	50.2	100.3	150.5	250.8	418.1	150	14.8	38.5	77	115.5	199.5	320.8
200	13.8	48.6	97.2	145.8	243.2	405.4	200	13.7	35.7	71.3	107	178.3	297.2
250	12.1	46.3	92.7	139	231.8	386.2	250	12.1	33.4	66.8	100.1	166.9	278.1
300	10.2	42.9	85.7	128.6	214.4	357.1	300	10.2	31.6	63.2	94.9	158.1	263.5
310	9.8	42.3	84.5	126.8	211.3	352	310	9.8	31.3	62.6	94	154.4	256.6

Note: 1 - For pressures and temperatures above these limits, please consult factory.

78 SERIES - Semi nozzle - API STD 526

Orifices Tables - Inlet x Outlet combinations according API STD 526 6Th Ed. 2009

POSRV 78 series															
Actual	in ²	0.124	0.222	0.352	0.568	0.887	1.457	FLANGE RATING ASME B 16.5							
	cm ²	0.800	1.432	2.271	3.665	5.723	9.400								
API	in ²	0.110	0.196	0.307	0.503	0.785	1.287	FLANGE RATING ASME B 16.5							
	cm ²	0.710	1.265	1.981	3.245	5.065	8.303								
ORIFICE		D		E		F		G		H		J		B 16.5	
SIZE	I	O	I	O	I	O	I	O	I	O	I	O	I	O	150 300 600 900 1500 2500
	1	1	1	1	1	1	1.5	1.5	2	3	150				
	1.5	1.5	1.5	1.5	1.5	1.5	2	2	2	3	3	4	150		
	1	1	1	1	1	1	1.5	1.5	1.5	1.5	2	3	3	300	
	1.5	1.5	1.5	1.5	1.5	1.5	2	2	2	2	3	4	4	300	
	1	1	1	1	1	1	1.5	1.5	1.5	1.5	2	3	3	600	
	1.5	1.5	1.5	1.5	1.5	1.5	2	2	2	2	3	4	4	600	
	1	1	1	1	1	1	1.5	1.5	1.5	1.5	2	3	3	900	
	1.5	1.5	1.5	1.5	1.5	1.5	2	2	2	2	3	4	4	900	
	1	1	1	1	1	1	1.5	1.5	1.5	1.5	2	3	3	1500	
1.5	1.5	1.5	1.5	1.5	1.5	2	2	2	2	3	4	4	1500		
1	1	1	1	1	1	1.5	1.5	1.5	1.5	2	3	3	2500		
1.5	1.5	1.5	1.5	1.5	1.5	2	2	2	2	-	-	-	2500		

POSRV 78 series																			
Actual	in ²	2.097	3.229	4.095	5.143	7.069	12.915	15.904	28.274	FLANGE RATING ASME B 16.5									
	cm ²	13.529	20.832	26.419	33.181	45.606	83.322	102.606	182.413										
API	in ²	1.838	2.853	3.600	4.340	6.380	11.050	16.000	26.000	FLANGE RATING ASME B 16.5									
	cm ²	11.858	18.406	23.226	28.000	41.161	71.290	103.226	167.742										
ORIFICE		K		L		M		N		P		Q		R		T			
SIZE	I	O	I	O	I	O	I	O	I	O	I	O	I	O	I	O	150 300 600 900 1500 600		
	3	4	3	4	4	6	4	6	4	6	4	6	6	8	6	8		8	10
	-	-	4	6	-	-	-	-	-	-	-	-	-	-	-	-		-	-
	3	4	3	4	4	6	4	6	4	6	4	6	6	8	6	8		8	10
	-	-	4	6	-	-	-	-	-	-	-	-	-	-	-	-		-	-
	3	4	3	4	4	6	4	6	4	6	4	6	6	8	6	8		8	10
	-	-	4	6	-	-	-	-	-	-	4	6	-	-	-	-		-	-
	3	4	3	4	4	6	4	6	4	6	-	-	-	-	-	-		-	-
	-	-	4	6	-	-	-	-	-	-	-	-	-	-	-	-		-	-
	3	4	3	4	4	6	4	6	4	6	-	-	-	-	-	-		-	-
-	-	4	6	-	-	-	-	-	-	-	-	-	-	-	-	-	-		
-	-	-	-	-	-	-	-	4	6	-	-	-	-	-	-	-	-		

For replacement only (former edition of API STD 526)

Orifices Tables - Inlet x Outlet combinations according API STD 526 - 1995 and before

POSRV 78 series															
Actual	in ²	0.124	0.222	0.352	0.568	0.887	1.457	FLANGE RATING ASME B 16.5							
	cm ²	0.800	1.432	2.271	3.665	5.723	9.400								
API	in ²	0.110	0.196	0.307	0.503	0.785	1.287	FLANGE RATING ASME B 16.5							
	cm ²	0.710	1.265	1.981	3.245	5.065	8.303								
ORIFICE		D		E		F		G		H		J		B 16.5	
SIZE	I	O	I	O	I	O	I	O	I	O	I	O	I	O	1500 2500
	-	-	-	-	-	-	-	-	-	-	-	-	-	2	
-	-	-	-	-	-	-	-	-	-	-	-	-	2	3	

POSRV 78 series																				
Actual	in ²	2.097	3.229	4.095	5.143	7.069	12.915	15.904	28.274	FLANGE RATING ASME B 16.5										
	cm ²	13.529	20.832	26.419	33.181	45.606	83.322	102.606	182.413											
API	in ²	1.838	2.853	3.600	4.340	6.380	11.050	16.000	26.000	FLANGE RATING ASME B 16.5										
	cm ²	11.858	18.406	23.226	28.000	41.161	71.290	103.226	167.742											
ORIFICE		K		L		M		N		P		Q		R		T				
SIZE	I	O	I	O	I	O	I	O	I	O	I	O	I	O	I	O	600 300 1500			
	-	-	-	-	-	-	-	-	-	-	-	-	-	-	-	6		8	6	8
	-	-	3	4	-	-	-	-	-	-	-	-	-	-	-	-		-	-	-

78 SERIES – Semi nozzle - API STD 526

Dimensions and Weights

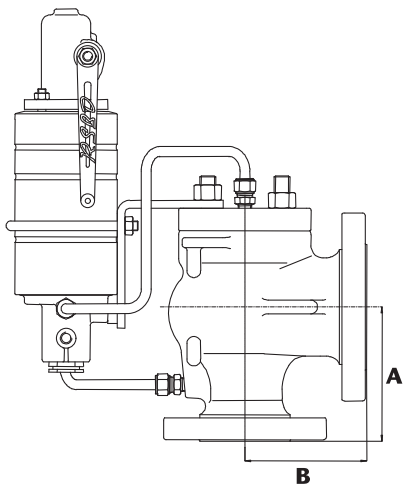
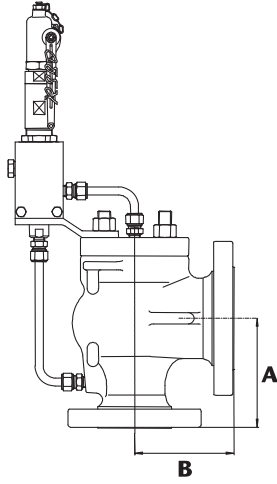

Size and Orifice (inch and API letter)			Flange rating (ASME B16.5)		Dimensions (mm)		Approx. Weight (kg)
Inlet	Orifice	Outlet	Inlet	Outlet	A	B	
1	D	2	150	150	104.78	114.3	27
1	D	2	300	150	111.13	114.3	27
1	D	2	600	150	111.13	114.3	27
1	D	2	900	300	125.41	120.65	38
1	D	2	1500	300	125.41	120.65	38
1	D	2	2500	300	125.41	120.65	40
1.5	D	2	150	150	123.83	120.65	30
1.5	D	2	300	150	123.83	120.65	30
1.5	D	2	600	150	123.83	120.65	30
1.5	D	2	900	300	149.23	139.7	40
1.5	D	2	1500	300	149.23	139.7	40
1.5	D	2	2500	300	149.23	139.7	45
1	E	2	150	150	104.78	114.3	27
1	E	2	300	150	111.13	114.3	27
1	E	2	600	150	111.13	114.3	27
1	E	2	900	300	125.41	120.65	38
1	E	2	1500	300	125.41	120.65	38
1	E	2	2500	300	125.41	120.65	40
1.5	E	2	150	150	123.83	120.65	30
1.5	E	2	300	150	123.83	120.65	30
1.5	E	2	600	150	123.83	120.65	30
1.5	E	2	900	300	149.23	139.7	40
1.5	E	2	1500	300	149.23	139.7	40
1.5	E	2	2500	300	149.23	139.7	45
1	F	2	150	150	104.78	114.3	27
1	F	2	300	150	111.13	114.3	27
1	F	2	600	150	111.13	114.3	27
1	F	2	900	300	125.41	120.65	38
1	F	2	1500	300	125.41	120.65	38
1	F	2	2500	300	125.41	120.65	40
1.5	F	2	150	150	123.83	120.65	30
1.5	F	2	300	150	123.83	120.65	30
1.5	F	2	600	150	123.83	120.65	30
1.5	F	2	900	300	149.23	139.7	40
1.5	F	2	1500	300	149.23	139.7	40
1.5	F	2	2500	300	149.23	139.7	45

78 SERIES – Semi nozzle - API STD 526

Dimensions and Weights

Size and Orifice (inch and API letter)			Flange rating (ASME B16.5)		Dimensions (mm)		Approx. Weight (kg)
Inlet	Orifice	Outlet	Inlet	Outlet	A	B	
1.5	G	3	150	150	130.18	123.83	33
1.5	G	3	300	150	130.18	123.83	35
1.5	G	3	600	150	130.18	123.83	36
1.5	G	3	900	300	161.93	171.45	45
1.5	G	3	1500	300	161.93	171.45	55
1.5	G	3	2500	300	161.93	171.45	55
2	G	3	150	150	136.53	123.83	35
2	G	3	300	150	136.53	123.83	36
2	G	3	600	150	136.53	123.83	37
2	G	3	900	300	166.69	171.45	47
2	G	3	1500	300	166.69	171.45	60
2	G	3	2500	300	177.80	171.45	60
1.5	H	3	150	150	130.18	123.83	35
1.5	H	3	300	150	130.18	123.83	35
1.5	H	3	600	150	130.18	123.83	38
1.5	H	3	900	300	161.93	171.45	50
1.5	H	3	1500	300	161.93	171.45	55
1.5	H	3	2500	300	161.93	171.45	57
2	H	3	150	150	136.53	123.83	37
2	H	3	300	150	136.53	123.83	37
2	H	3	600	150	136.53	123.83	40
2	H	3	900	300	166.69	171.45	55
2	H	3	1500	300	166.69	171.45	60
2	H	3	2500	300	177.80	171.45	62
2	J	3	150	150	136.53	123.83	37
2	J	3	300	150	136.53	123.83	38
2	J	3	600	150	136.53	123.83	45
2	J	3	900	300	166.69	171.45	60
2	J	3	1500	300	166.69	171.45	70
2	J	3	2500	300	177.80	171.45	80
3	J	4	150	150	155.58	161.93	40
3	J	4	300	150	155.58	161.93	45
3	J	4	600	150	161.93	161.93	56
3	J	4	900	300	190.50	180.98	81
3	J	4	1500	300	190.50	180.98	82
3	K	4	150	150	155.58	161.93	47
3	K	4	300	150	155.58	161.93	48
3	K	4	600	150	161.93	161.93	65
3	K	4	900	300	190.50	180.98	75
3	K	4	1500	300	190.50	180.98	85

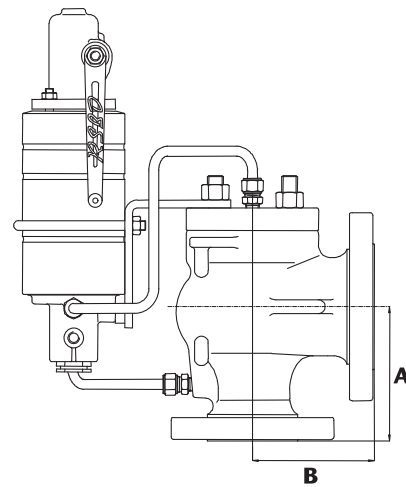
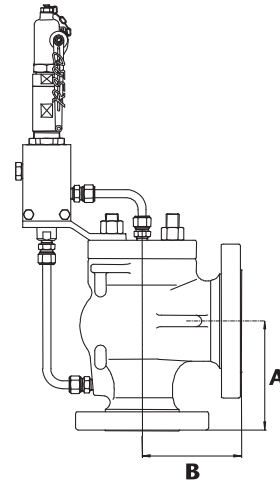

78 SERIES – Semi nozzle - API STD 526

Dimensions and Weights

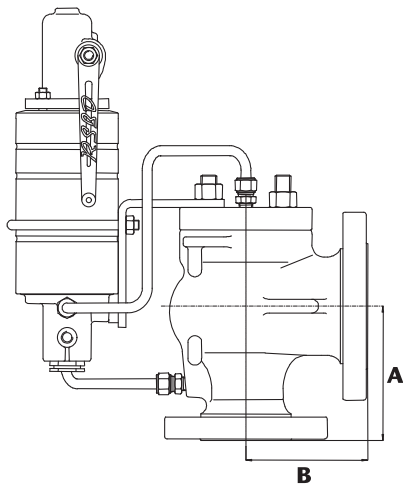
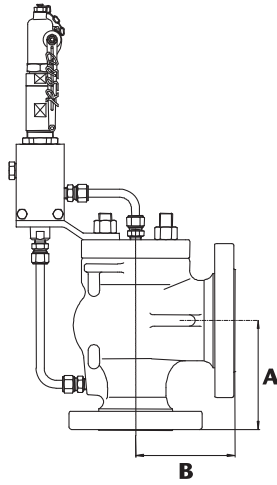

Size and Orifice (inch and API letter)			Flange rating (ASME B16.5)		Dimensions (mm)		Approx. Weight (kg)
Inlet	Orifice	Outlet	Inlet	Outlet	A	B	
3	L	4	150	150	155.58	161.93	47
3	L	4	300	150	155.58	161.93	48
3	L	4	600	150	161.93	161.93	60
3	L	4	900	300	190.5	180.98	65
3	L	4	1500	300	190.5	180.98	70
4	L	6	150	150	196.85	209.55	80
4	L	6	300	150	196.85	209.55	100
4	L	6	600	150	196.85	209.55	105
4	L	6	900	300	249.24	233.36	115
4	L	6	1500	300	249.24	233.36	118
4	M	6	150	150	196.85	209.55	75
4	M	6	300	150	196.85	209.55	80
4	M	6	600	150	196.85	209.55	100
4	M	6	900	300	249.24	233.36	155
4	M	6	1500	300	249.24	233.36	170
4	N	6	150	150	196.85	209.55	75
4	N	6	300	150	196.85	209.55	80
4	N	6	600	150	196.85	209.55	100
4	N	6	900	300	249.24	233.36	155
4	N	6	1500	300	249.24	233.36	170
4	P	6	150	150	196.85	209.55	75
4	P	6	300	150	196.85	209.55	80
4	P	6	600	150	196.85	209.55	100
4	P	6	600	300	249.24	233.36	120
4	P	6	900	300	249.24	233.36	150
4	P	6	1500	300	249.24	233.36	170
4	P	6	1500	600	249.24	263.52	200
6	Q	8	150	150	239.71	241.3	170
6	Q	8	300	150	239.71	241.3	180
6	Q	8	600	150	246.06	241.3	215
6	Q	8	600	300	246.06	265.11	230
6	R	8	150	150	239.71	241.3	170
6	R	8	300	150	239.71	241.3	180
6	R	8	600	150	246.06	241.3	215
8	T	10	150	150	276.23	279.4	255
8	T	10	300	150	276.23	279.4	260
8	T	10	600	150	296.86	279.4	280

86 SERIES – Full nozzle - API STD 526
Tables 2 to 15 dimensions

Materials for standard applications, high and very high temperatures.

The 86 series is a steam pressure safety valve.

The design of 86 series is then dedicated to saturated and superheated steam.

The 86 series is only supplied with our DCS or DCM pilot (depending on the conditions).

The perfect gliding of the piston in the guide is allowed with our special Thermoglide rings. It avoids the seizing and glides with less friction than a standard metal to metal gliding.

The dimensions A and B and the orifices of the 86 series comply with the ones of our Starflow and 76 series (spring loaded tables in API Std 526).

Please note that if you wish to connect the sensing line on the valve inlet with a flange finish different than Raised Face (through the nozzle base thickness), the A dimension (on small PSV sizes) could deviate from API STD 526. Please consult the factory.

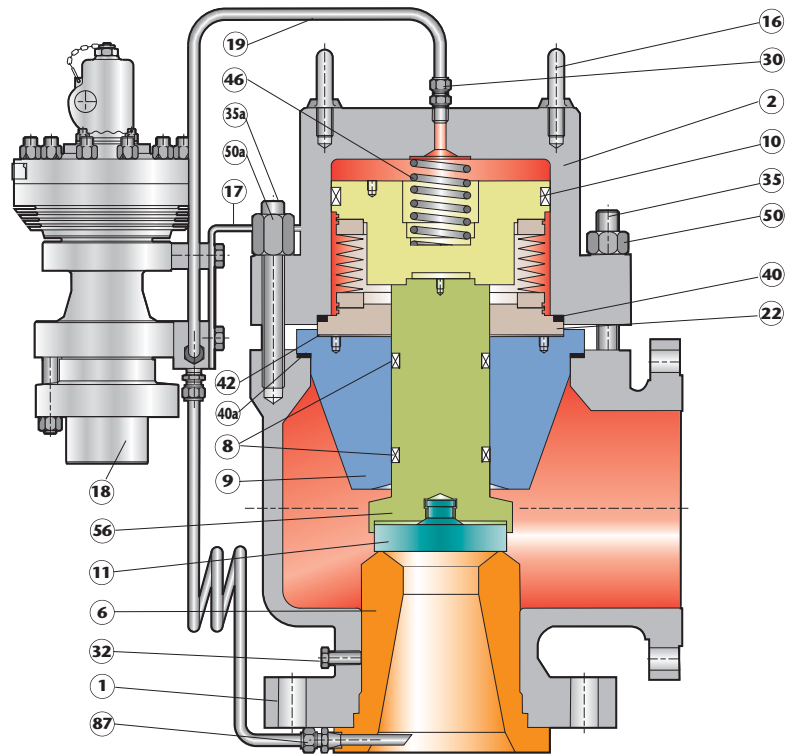

Tag	Designation	Standard materials for temperatures up to 427 °C	Standard materials for high temperatures up to 538 °C
1	Body	SA 216 Gr WCC	SA 217 Gr WC6
2	Cover	SS 321	SS 321
6	Nozzle	SS 321	SS 321
8	Lower Piston Ring	Thermoglide™	Thermoglide™
9	Guide	SS 316L	SS 316L
10	Upper Piston Ring	Thermoglide™	Thermoglide™
11	Disc	Z6NCTD25.15	Z6NCTD25.15
16	Lifting Eye Bolt	CS	CS
17	Bracket	SS	SS
18	Pilot	SS	SS
19	Dome Line	SS	SS
22	Bellows	SS 321	SS 321
30	Dome Line Fitting	SS	SS
32	Drain Plug	SS 316	SS 316
35	Stud	SA 193 Gr B16	SA 193 Gr B16
35a	Stud	SA 193 Gr B16	SA 193 Gr B16
40	Cover Gasket	Graphite	Graphite
40a	Guide Gasket	SS + Graphite	SS + Graphite
42	Bellows Gasket	SS + Graphite	SS + Graphite
46	Return Spring	Alloy X750	Alloy X750
50	Nut	SA 194 Gr 7	SA 194 Gr 7
50a	Nut	SA 194 Gr 7	SA 194 Gr 7
56	Lower Piston	SS 316L	316L
56	Upper Piston	SS 316L	SS 316L
87	Sensing Line Fitting	SS	SS

Note: Other materials on request.

71 Series - Codification

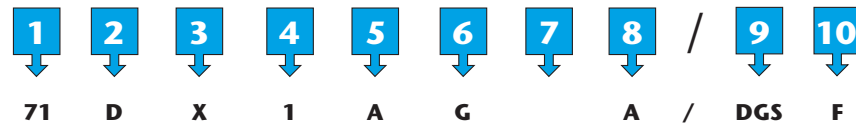

- 1** → **Type : 71**
- 2** → **Orifice Designation:**
- B
 - According to API Std 526: D-E-F-G
- 3** → **Configuration:**
- A : A 216 Gr WCC
 - X : A 351 Gr CF3M
- 4** → **Valve Rating (ASME):**
- | | |
|----------|-----------|
| 1 : 150# | 4 : 900# |
| 2 : 300# | 5 : 1500# |
| 3 : 600# | 6 : 2500# |
- 5** → **Connection Type:**
- A : ASME B16.5 and EN 1759-1
 - P : EN 1092-1
 - K : Inlet Male Conical BSP/Outlet Female Cylindrical BSP
 - N : Inlet Male NPT/Outlet Female NPT
 - N2 : Inlet Female NPT/Outlet Female NPT
- 6** → **Inlet Size:**
- F : ½" (DN15)
 - G : ¾" (DN20)
 - H : 1" (DN25)
 - K : 1 ½" (DN40)
- 7** → **Outlet Size (orifice B only):**
- F : ½" (DN15)
 - H : 1" (DN25)
- 8** → **Options:**
- A : No options
 - Z : Miscellaneous
- 9** → **Pilot:**
- DGS B : non flowing pop action (gas only) up to 150 barg
 - DGS B HP : non flowing pop action (gas only) over 150 barg to 431 barg
- 10** → **Pilot Options:**
- F : Lever (packed)
 - V : Test gag

76 Series - Codification

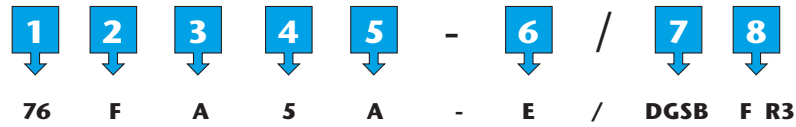

Type : 76

- full nozzle pilot safety relief valve
- metal seat



Orifice Designation:

- According to API Std 526: D-E-F-G-H-J-K-L-M-N-P-Q-R-T
- Additional non standard orifices: S-U-V-W



Configuration:

- A : A 216 Gr WCC
- L : A 352 Gr LCC
- X : A 351 Gr CF8M
- A201, A204 and A206 : Alloy 20
- AL1, AL4 and AL6 : Alloy 625
- AY1, AY4 and AY6 : Alloy 825
- AV1, AV4 and AV6 : Alloy 254 SMO
- CN1, CN4 and CN6 : A 351 Gr CN3MN
- D1, D4 and D6 : Duplex
- H1, H4 and H6 : Alloy C
- M1, M4 and M6 : Alloy Nickel/Copper
- SD1, SD4 and SD6 : Superduplex
- MRA and MRB : NACE MR0103
- SGA and SGB : NACE MR0175 / ISO 15156



Valve Rating (ASME):

- 1 : 150#
- 2 : 300#
- 3 : 600#
- 4 : 900#
- 5 : 1500#
- 6 : 2500#
- 7 : 300# light



Flange Type:

- A : ASME B16.5 and EN 1759-1
- P : EN 1092.1



Options:

- A : No options
- E : Remote sensing line
- F : Filter
- F2 : 2 Filters
- I : Back flow preventer
- N : NACE MR0175/ISO 15156 last edition compliant
- O : Pilot vented to body bowl
- T : Field test connector
- T1 : Internal configuration for 2.4 barg <SP <7 barg (not managed by user)
- U : UV stamp
- V : Buffer tank
- Y1 : Remote opening



Pilot:

- DGS B : non flowing pop action (gas only) up to 150 barg
- DGS B HP : non flowing pop action (gas only) over 150 barg to 431 barg
- DCS B : non flowing modulating pilot (gas, liquid, steam)



Pilot Options:

	DGS B	DGS B HP	DCS B
C : Closing damper			X
D : Differential pressure			X
F : Lever (packed)	X	X	X
H : Alloy X750 spring (NACE MR0175/ISO 15156)			X
R1 : Spring 1 DaN			X
R3 : Spring 3 DaN			X
V : Test Gag	X	X	X
D1 : Wetted parts in Duplex			X
D6 : All parts in Duplex			X
I1 : Wetted parts in Alloy 625			X
I6 : All parts in Alloy 625			X
EM1 : Wetted parts in other Exotic Materials			X
EM6 : All parts in Exotic Materials			X

The information given is for guidance only and can be revised without previous notice. They cannot replace an appropriate technical characteristic design.

78 Series - Codification

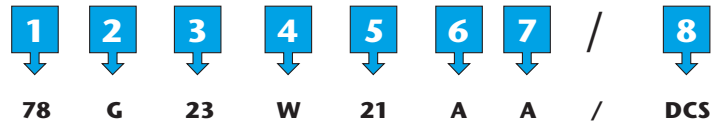

- 1** → **Type : 78**
 - semi nozzle pilot operated valve
 - soft seat
- 2** → **Orifice Designation:** (according to API Std 526)
 - D-E-F-G-H-J-K-L-M-N-P-Q-R-T
 - Additional non standard orifices: V - W
- 3** → **Inlet x Outlet :**

1 : 1" (DN 25)	5 : 2 1/2" (DN 65)
2 : 2" (DN 50)	6 : 6" (DN 150)
3 : 3" (DN 80)	7 : 1 1/2" (DN 40)
4 : 4" (DN 100)	8 : 8" (DN 200)
- 4** → **Configuration:**
 - W : A 216 Gr WCC
 - L : A 352 Gr LCC
 - X : A 351 Gr CF8M
 - A206 : Alloy 20
 - AL6 : Alloy 625
 - AY6 : Alloy 825
 - AV6 : Alloy 254 SMO
 - CN6 : A 351 Gr CN3MN
 - D6 : Duplex
 - H6 : Alloy C
 - M6 : Alloy Nickel/Copper
 - SD6 : Superduplex
 - MRA and MRB : NACE MR0103
 - SGA and SGB : NACE MR0175 / ISO 15156
- 5** → **Valve Rating (ASME):**

1 : 150#	4 : 900#
2 : 300#	5 : 1500#
3 : 600#	6 : 2500#
- 6** → **Machining of inlet Flanges:**
 - A : ASME or EN 1759-1 (Outlet flange according to API STD 526)
 - P : EN 1092-1 (PN10-16-25-40) - on application (please consult factory)
- 7** → **Options:**
 - A : without option
 - O : with option (to be listed)
 - Z : special
- 8** → **Pilot:**
 - DGSB : non flowing pop action (gas service)
 - DCSB : non flowing modulating (gas - liquid)
 - DMS : non flowing modulating pilot (gas - liquid)
- 9** → **Pilot Options:**

	DGS B	DGS B HP	DCS B
C : Closing damper			X
D : Differential pressure			X
F : Lever (packed)	X	X	X
H : Alloy X750 spring (NACE MR0175/ISO 15156)			X
R1 : Spring 1 DaN			X
R3 : Spring 3 DaN			X
V : Test Gag	X	X	X
D1 : Wetted parts in Duplex			X
D6 : All parts in Duplex			X
I1 : Wetted parts in Alloy 625			X
I6 : All parts in Alloy 625			X
EM1 : Wetted parts in other Exotic Materials			X
EM6 : All parts in Exotic Materials			X

The information is given for guidance only and can be revised without previous notice.
They cannot replace an appropriate technical characteristic design

86 Series - Codification

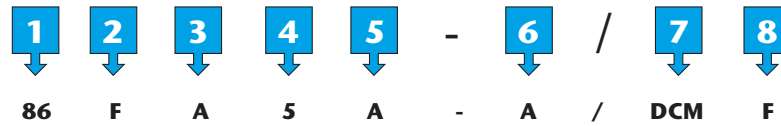

- 1** → **Type : 86**
 - Full nozzle pilot safety relief valve
 - Metal seat
- 2** → **Orifice Designation:**
 - According to API Std 526: D-E-F-G-H-J-K-L-M-N-P-Q-R-T
 - Additional non standard orifices: S-U-V-W
- 3** → **Configuration:**
 - A : A 216 Gr WCC
 - L : A 352 Gr LCC
 - X : A 351 Gr CF8M
- 4** → **Valve Rating (ASME):**
 - 1 : 150# 4 : 900# 7 : 300# light
 - 2 : 300# 5 : 1500#
 - 3 : 600# 6 : 2500#
- 5** → **Flange Type:**
 - A : ASME B16.5 and EN 1759-1
 - P : EN 1092.1
- 6** → **Options:**
 - A : No options
 - E : Remote sensing line
 - F : Filter
 - I : Back flow preventer
 - O : Pilot vented to body bowl
 - T : Field test connector
 - T1 : Internal configuration for 2.4 barg <SP <7 barg (not managed by user)
 - U : UV stamp
 - V : Buffer tank
 - Y1 : Remote opening
- 7** → **Pilot:**
 - DCSB : non flowing pilot (gas, liquid, steam)
 - DCM : very high temperature steam pilot
- 8** → **Pilot Options:**

	DCS B	DCM
C : Closing damper	X	X
D : Differential pressure	X	
F : Lever (packed)	X	X
H : Alloy X750 spring (NACE MR0175/ISO 15156)	X	
R1 : Spring 1 DaN	X	
R3 : Spring 3 DaN	X	
V : Test gag	X	X

The information is given for guidance only and can be revised without previous notice. They cannot replace an appropriate technical characteristic design

Spring Loaded Safety Relief Valves

Body in carbon steel, stainless steel, alloy and exotic materials; with bellows, lever and other accessories, to ensure suitability for all service conditions.



Starflow S5 (steam only)
 ASME Section VIII Div. 1
 (UV Stamp)
 API Std 526
 Full Nozzle - Enlarged guide
 Inlet size : 1" to 12"
 Rating : 150# to 2500#
 Temp : up to 540°C

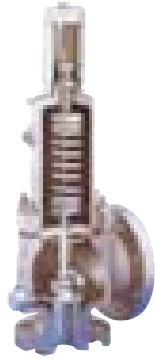

Starflow P3/P4/PS
 ASME Section VIII Div. 1
 (UV Stamp)
 API Std 526
 Full Nozzle
 Inlet size : 1" to 12"
 Rating : 150# to 2500#
 Temp : -196°C up to +540°C



63 Series
 ISO 4126
 Semi-nozzle
 Inlet size : 3/4" to 10"
 Rating : 150# to 300#
 Temp : -196°C up to +330°C



9 Series
 ASME Section VIII Div. 1
 Portable SRV - Full nozzle
 Screwed/Flanged/Welded
 Size : 1/2" to 1 1/2"
 Rating : 150# to 2500#
 Temp : -196°C up to +400°C



Starvalve Changeover Valves
 Low pressure drop COV
 Standard COV
 Combined valve with linkage system
 Sizes : 1/2" - 10"
 Pressure : up to 100 barg
 Temp : -196°C up to +427°C
 Mat : CS - SS

Pilot Operated Safety Relief Valves

The Sarasin-RSBD pilot-operated safety relief valve is an autonomous valve. It does not need any auxiliary source of power to operate. The advanced technology of Sarasin-RSBD valves has been adopted by the nuclear industry, French and U.S. Navies and by the Oil & Gas industries. It is complementary to the range of spring-loaded safety relief valves and covers a wide field of applications including severe conditions.



76 Series
 Full nozzle
 API spring loaded SRV dimensions



78 Series
 Semi nozzle
 API POSRV dimensions

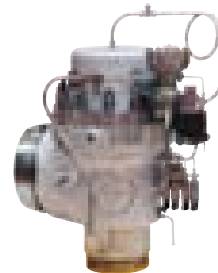

86 Series
 Hot service - Full nozzle
 API spring loaded SRV dimensions
 Set pressure : up to 180 barg
 Temp : up to 550°C

Advantages of the Sarasin-RSBD Pilot-operated safety relief valve

- leak-free pilot
- on-off opening, fully open or closed (limited maintenance)
- perfect tightness (no production loss)
- perfect operation, even with capacities smaller than those rated for all types of fluids
- excellent repeatability and reliability
- adjustable blowdown (pop action)
- no pressure/flow limit
- with additional equipment (solenoid valve), the safety relief valve can be used as a discharge valve.

To meet the most varied requirements, Sarasin-RSBD selects the appropriate pilot detector for the safety relief valve required (semi or full nozzle, with bellows, piston etc.)



71 Series
 Portable - Full nozzle



Gas - Liquid
 Modulating action



Gas
 Pop action



High temperature steam - Gas
 Pop action



Atwood & Morrill
Engineered Valve Products & Solutions

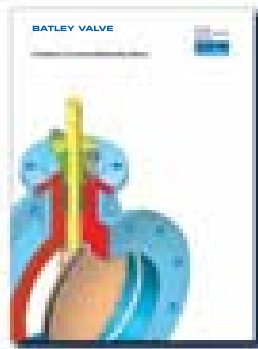

Batley Valve
Isolation & Control Butterfly Valves



Blakeborough
Choke Valves

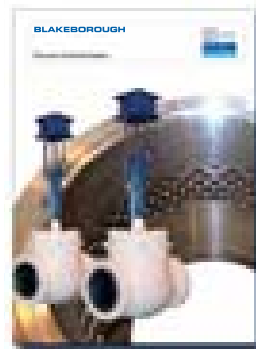

Blakeborough
Process Control Valves



Blakeborough
X-Stream™ Control Valves



Hopkinsons
Gate, Globe & Special Purpose Valves



Hopkinsons
Shell Boiler Mountings

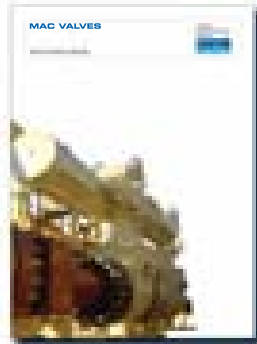

MAC Valves
Valve Product Range



MAC Valves
Rotary Gate & Dosage Valves



Sarasin-RSBD
Safety Relief Valves - Starflow

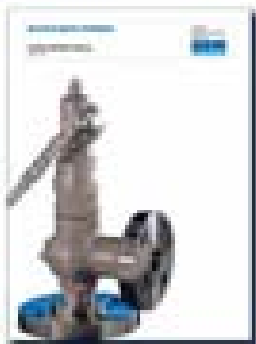

Sarasin-RSBD
Safety Relief Valves - Series 9



Sarasin-RSBD
Spring Loaded Safety Relief Valves - 63 Series



Sarasin-RSBD
Changeover Valves - Starvalve



Sarasin-RSBD
Pilot Operated Safety Relief Valves - 71, 76, 78 & 86 Series



Sarasin-RSBD
Tank Blanketing System Starblanketer - 77 Series



Sarasin-RSBD
Technical Information



Sarasin-RSBD
Pressure Safety Valves & Safety Devices

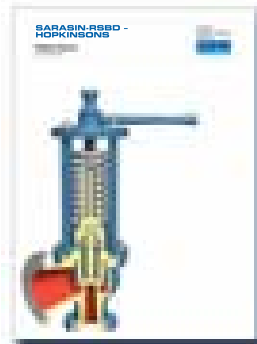

Sarasin-RSBD Hopkinsons
Safety Valves - A7000 Series



Sebim
Nuclear Pilot Operated Safety Relief Valves

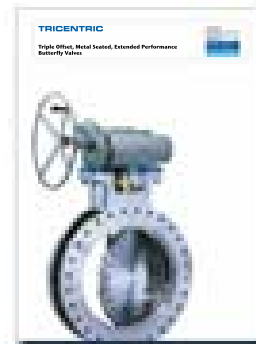

Tricentric
Triple Offset Butterfly Valves



Roto-jet Pump
High Pressure Pumps -
Models 2100 & 2200



Roto-jet Pump
High Pressure Pumps -
Models RG & RO



Roto-jet Pump
High Pressure Pumps -
Models R11, API R11 & RD11

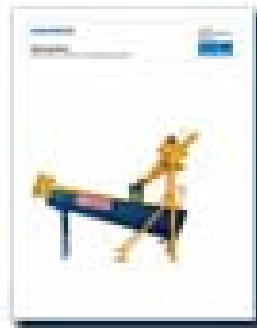

Wemco
Hydrogritter



Wemco Pump
Model CF Chop-Flow Pump

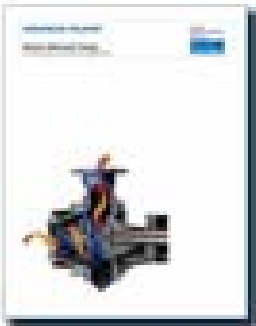

Wemco Pump
Wemco Hidrostal Pumps



Wemco Pump
Wemco Submersible Pumps

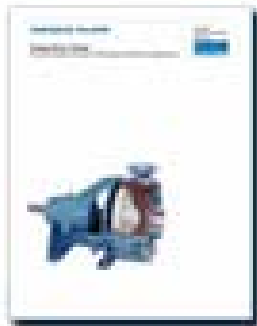

Wemco Pump
Torque-Flow Pumps



Wemco Self Primer
Self Primer



Weir Services
Parts Supply and Overhaul of
Steam Turbines



Weir Services
Repair and Overhaul Facilities



Weir Services
Pump Maintenance

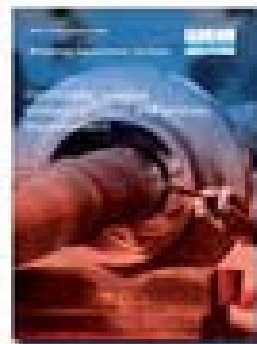

Weir Services
Rotating Equipment Services



Weir Services
High Integrity Spare Parts



Weir Services
Hydroelectric Plant Rehabilitation

Weir Power
& Industrial
application
information

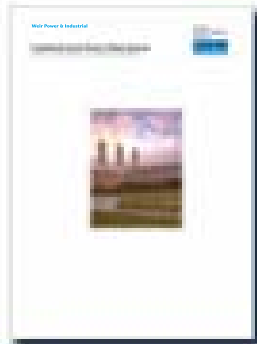

Fossil Fuel Power Plant System

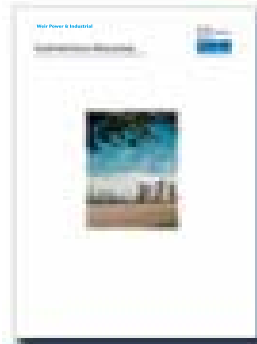

Multi Stage Flash Desalination
Plant System

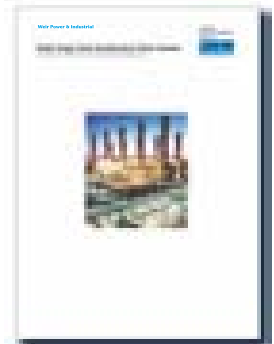

Combined Cycle Power Plant
System

Weir Power & Industrial France SAS

SEBIM

ZI La Palunette
13220 Chateauneuf Les Martigues - France
Tel: +33 (0) 4 42 07 00 95
Fax: +33 (0) 4 42 07 11 77
Email: coseb@weirgroup.com

SARASIN-RSBD

Rue J.B. Grison - ZI Bois Rigault
62880 Vendin Le Vieil - France
Tel: +33 (0) 3 21 79 54 50
Fax: +33 (0) 3 21 28 62 00
Email: sarasin.rsbd@weirgroup.com

Excellent
Power & Industrial
Solutions

